

TECHNICAL MANUAL
DIRECT SUPPORT
MAINTENANCE MANUAL
(INCLUDING REPAIR PARTS AND SPECIAL TOOLS)
FOR

GENERATOR, ALTERNATING CURRENT,
200 AMPERES (Leece-Neville)
NSN 2920-01-147-1575
NSN 2920-01-238-9710

AND

GENERATOR, ALTERNATING CURRENT,
200 AMPERES (Niehoff)
NSN 2920-01-292-2993
NSN 2920-01-298-8072

Distribution Statement A:
Approved for public Release; distribution is unlimited.

HEADQUARTERS, DEPARTMENT OF THE ARMY
31 May 1987

CHANGE

No. 1

C1
 HEADQUARTERS
 DEPARTMENT OF THE ARMY
 WASHINGTON D.C., 20 APRIL 2000

TECHNICAL MANUAL
 DIRECT SUPPORT MAINTENANCE MANUAL
 (INCLUDING REPAIR PARTS AND SPECIAL TOOLS)
 GENERATOR, ALTERNATING CURRENT,
 200 AMPERES (Leece-Neville)
 NSN 2920-01-147-1575
 NSN 2920-01-238-9710
 AND
 GENERATOR, ALTERNATING CURRENT,
 200 AMPERES (Niehoff)
 NSN 2920-01-292-2993
 NSN 2920-01-298-8072

TM 9-2920-257-30&P, 31 May 1987, is changed as follows:

1. Title is changed to reflect added new equipment, Generator, Alternating Current, 200 Amperes, NSN 2920-01-292-2993, 2920-01-238-9710, and 2920-01-298-8072.
2. Remove old pages and insert new pages as indicated below.
3. New or changed material is indicated by a vertical bar in the margin of the page.

Remove Pages

i and ii
 None
 1-1/ (1-2 Blank)
 2-1 and 2-2
 2-15/ (2-16 Blank)
 None
 3-1 and 3-2
 None
 A-1/ (A-2 Blank)
 B-1/ (B-2 Blank)
 D-1/ (D-2 Blank)
 E-7/ (E-8 Blank)
 F-7 and F-8
 Cover

Insert Pages

i and ii
 iii (iv Blank)
 1-1(1-2 Blank)
 2-1 and 2-2
 2-15 and 2-16
 2-17 thru 2-23/ (2-24 Blank)
 3-1 and 3-2
 3-29 thru 3-40
 A-1 thru A-2
 B-1/ (B-2 Blank)
 D-1/ (D-2 Blank)
 E-7/ (E-8 Blank)
 F-7 and F-8
 Cover

The distribution has been changed from restricted to Distribution Statement A.

Approved for public release; distribution is unlimited.

By Order of the Secretary of the Army:

ERIC K. SHINSEKI
General, United States Army
Chief of Staff

Official:

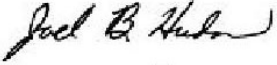

JOEL B. HUDSON
Administrative Assistant to the
Secretary of the Army
0005501

DISTRIBUTION: To be distributed in accordance with the Initial Distribution Number (IDN) 380719 requirements for TM 9-2920-257-30&P.

WARNING

This list summarizes critical **WARNINGS** in this manual. They are repeated here to let you know how important they are. Study these **WARNINGS** carefully; they can save your life and the lives of personnel with whom you work.

WARNING



Dry cleaning solvent P-D-680 is toxic and flammable. Wear protective goggles and gloves and use only in a well ventilated area. Avoid contact with skin, eyes, and clothes and don't breathe vapors. Do not use near open flame or excessive heat. The flash point is 100°F-138°F (38°-59°C). If you become dizzy while using cleaning solvent, get fresh air immediately and get medical aid. If contact with eyes is made, wash your eyes with water and get medical aid immediately.

WARNING



Air pressure in excess of 30 psi (207 kpa) can injure personnel. Do not direct pressurized air at yourself or others. Always wear goggles.

WARNING



Energized systems and equipment can bum you. If **MASTER SWITCH** is **ON**, electrical system and equipment will be energized. Make sure **MASTER SWITCH** is **OFF** when you work on electrical systems or equipment.

CHANGE

No. 1

TECHNICAL MANUAL

DIRECT SUPPORT MAINTENANCE MANUAL
 (INCLUDING REPAIR PARTS AND SPECIAL TOOLS)
 GENERATOR, ALTERNATING CURRENT,
 200 AMPERES (Leece-Neville)
 NSN 2920-01-147-1575
 NSN 2920-01-238-9710
 AND
 GENERATOR, ALTERNATING CURRENT,
 200 AMPERES (Niehoff)
 NSN 2920-01-292-2993
 NSN 2920-01-298-8072

Approved for public release; distribution is unlimited.

REPORTING ERRORS AND RECOMMENDING IMPROVEMENTS

You can help improve this manual. If you find mistakes, or if you know a way to improve the procedures, please let us know. Mail you letter, DA Form 2028 (Recommended Changes to Publications and Blank Forms), or DA Form 2028-2 located in the back of this manual, directly to: Commander, U.S. Army Tank-Automotive and Armaments Command, ATTN: AMSTA-AC-NML, Rock Island, IL 61201-9948. A reply will be furnished to you TABLE OF CONTENTS

Chapter	Page
1 INTRODUCTION	1-1
Section	
I. GENERAL.....	1-1
1-1. Scope	1-1
1-2. Reporting Equipment Improvement	1-1
Recommendations (EIR)	1-1
II. SPECIAL TOOLS AND EQUIPMENT.....	1-1
1-3. Fabricated Tools	1-1
1-4. Special Equipment	1-1

TABLE OF CONTENTS - Continued

Chapter		Page
2	GENERATOR TROUBLESHOOTING	2-1
	Section	
	I. General	2-1
	2-1. General Instructions and Procedures	2-1
	2-2. On-Vehicle Test	2-1
	II. PN 2260AC and A0012266AA (Leece-Neville)	2-2
	2-3. Troubleshooting Procedures	2-2
	III. PN N1205 and N1206 (Niehoff)	2-16
	2-4. On-Vehicle Test	2-16
	2-5. Test Set-Up	2-16
	2-6. General Test Procedures	2-17
	2-7. Bench Test Procedures	2-18
	2-8. Static Test Procedures	2-19
3	GENERATOR MAINTENANCE	3-1
	Section	
	I. PN 2260AC and A0012266AA (Leece-Neville)	3-1
	3-1. Construction	3-1
	3-2. General Instructions	3-1
	3-3. Generator Repair Instructions	3-1
	II. PN N1205 and N1206 (Niehoff)	3-29
	3-4. General Instructions	3-29
	3-5. Generator Repair Instructions	3-29
APPENDIX A	REFERENCES	A-1
APPENDIX B	EXPENDABLE SUPPLIES AND MATERIALS LIST	B-1
APPENDIX C	DIRECT SUPPORT MAINTENANCE	
	REPAIR PARTS AND SPECIAL TOOLS	C-1
	I. INTRODUCTION	C-1
	C-1. Scope	C-1
	C-2. General	C-1
	C-3. Explanation of Columns	C-2
	C-4. Special Information	C-7
	C-5. How To Locate Repair Parts	C-7
	II. REPAIR PARTS LIST	C-9
	III. SPECIAL TOOLS LIST	C-12
	IV. NSN AND PART NUMBER INDEX	C-13
APPENDIX D	TOOL AND EQUIPMENT REQUIREMENTS	D-1
APPENDIX E	TEST STAND PROCEDURES	E-1
	E-1. General	E-1
	E-2. Calibration	E-1
	E-3. Base Setting for UMC Switches	E-2
	E-4. 200 AMP Bench Tests	E-5
APPENDIX F	Fabricated Equipment	F-1

CHAPTER 1

INTRODUCTION

Section I. GENERAL

1-1. SCOPE

This manual provides instructions for repairing and testing the 200-ampere generators, PN 2260AC, NSN 2920-01-147-1575, PN A0012266AA, NSN 2920-01-238-9710, PN N1205, NSN 2920-01-298-8072, and PN N1206, NSN 2920-01-292-2993. Throughout this manual the generators will be referred to by part number.

1-2. REPORTING EQUIPMENT IMPROVEMENT RECOMMENDATIONS (EIR)

If equipment needs improving, let us know. Send us an EIR. You, the user, are the only one who can tell us what you don't like about your equipment. Let us know why you don't like the design. Put it on an SF368 (Quality Deficiency Report). Mail it to Commander, U. S. Army Tank-Automotive and Armament Command, Attn: AMSTA-IM-OP, Warren, MI 48397-5000. We'll send you a reply.

Section II. SPECIAL TOOLS AND EQUIPMENT

1-3. FABRICATED TOOLS

Generator disassembly and assembly requires the use of fabricated tools. See Appendix F for materials and dimensions required to fabricate the necessary tools. Fabricate special wiring harnesses to test generators on the test stand, see Appendix F.

1-4. SPECIAL EQUIPMENT

Appendix D lists common tool sets, supplemental sets, and special tools/fixtures needed to maintain the 200-ampere generator.

CHAPTER 2

GENERATOR TROUBLESHOOTING

Section I. General

2-1. GENERAL INSTRUCTIONS AND PROCEDURE

a. This chapter contains troubleshooting information and procedures for locating and correcting malfunctions in the various component parts of the generators.

b. Perform inspection of the generator after removal from the vehicle or engine to verify any diagnosis made when the unit was mounted on the vehicle or engine, to uncover further defects, or to determine malfunctions. This inspection is important because it is often your only means of determining the malfunction without completely disassembling the generator.

c. Troubleshoot a disabled generator, after removal from the engine, by subjecting it to tests described in this manual.

d. A multimeter will be used for ampere, volt and ohm testing.

2-2. ON VEHICLE TEST

a. It is easier to examine the generator on the vehicle, by examining the charging and ignition systems of the vehicle at the same time.

b. Refer to respective vehicle operator's and/or maintenance manuals to verify:

(1) Vehicle belt tension

(a) Use belt tension gauge for appropriate belting system.

(2) Battery condition

(a) Battery must be in good condition and fully charged.

(3) Electrical connection in the charging circuit

(a) Make sure all connections are clean, tight, and free of corrosion.

(4) Ignition circuit

(a) Check for 24 volts nominal at regulator pin F.

Section II. PN 2260AC AND A0012266AA (Leece-Neville)

2-3. TROUBLESHOOTING PROCEDURES

- a. After the direct support unit receives the generator, make a preliminary inspection: before installation on an engine, or when there is an unknown cause of failure.
- b. Discover the cause for failure, then disassemble and repair before proceeding with prescribed tests. Performing additional operational tests on a damaged generator will only increase the damage.

Table 2-1. Generator Troubleshooting

MALFUNCTION	TEST OR INSPECTION	CORRECTIVE ACTION
-------------	--------------------	-------------------

GENERATOR FAILS TO CHARGE, OR OVERCHARGES, OR RUNS AT FULL FIELD VOLTAGE.

NOTE

Complete all steps in troubleshooting procedure unless otherwise indicated, because one type of fault condition can cause other fault conditions and more than one generator component could be defective.

- Step 1. Remove cover plate, connector assembly and mounting plate, and printed circuit panel assembly, brushes and brush holder in accordance with paragraph 3-3b.
- Step 2. Refer to figure 3-2 and remove three nuts (10) and six rectifier leads from three stator terminal studs.

Table 2-1. Generator Troubleshooting - Continued

MALFUNCTION	TEST OR INSPECTION	CORRECTIVE ACTION
-------------	--------------------	-------------------

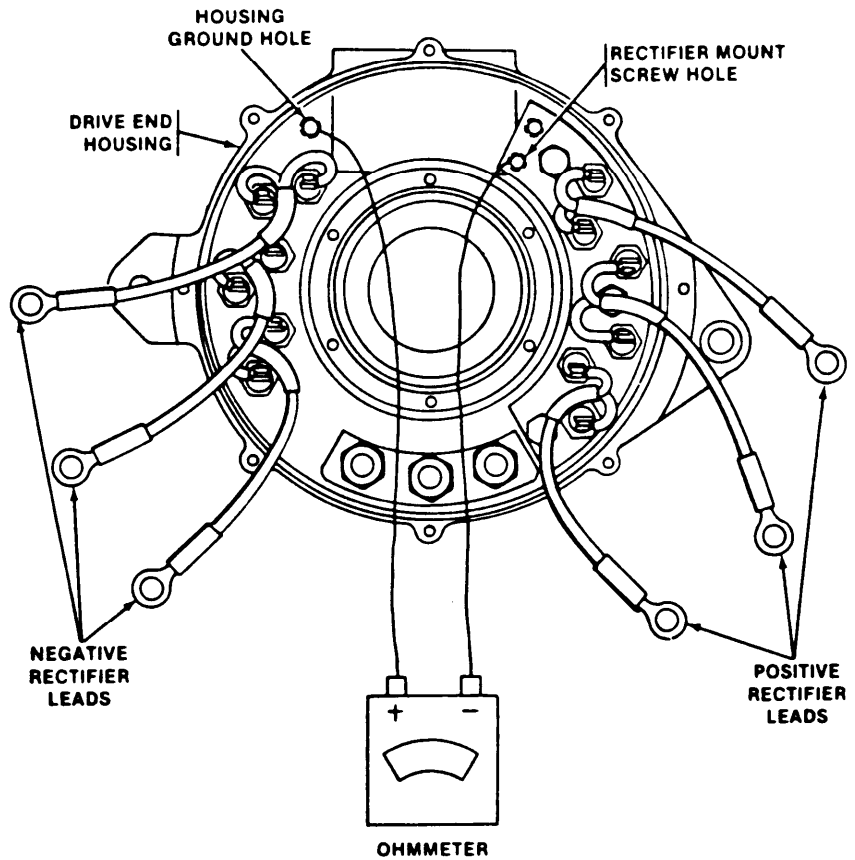

Figure 2-1. Rectifier Mount Ground Test

Step 3. Check for ground between positive rectifier mount and generator frame in accordance with figure 2-1.

If ohmmeter reading is less than 50,000 ohms, replace drive end housing assembly in accordance with paragraph 3-3 and go to step 8.

Table 2-1. Generator Troubleshooting - Continued

MALFUNCTION	TEST OR INSPECTION	CORRECTIVE ACTION
-------------	--------------------	-------------------

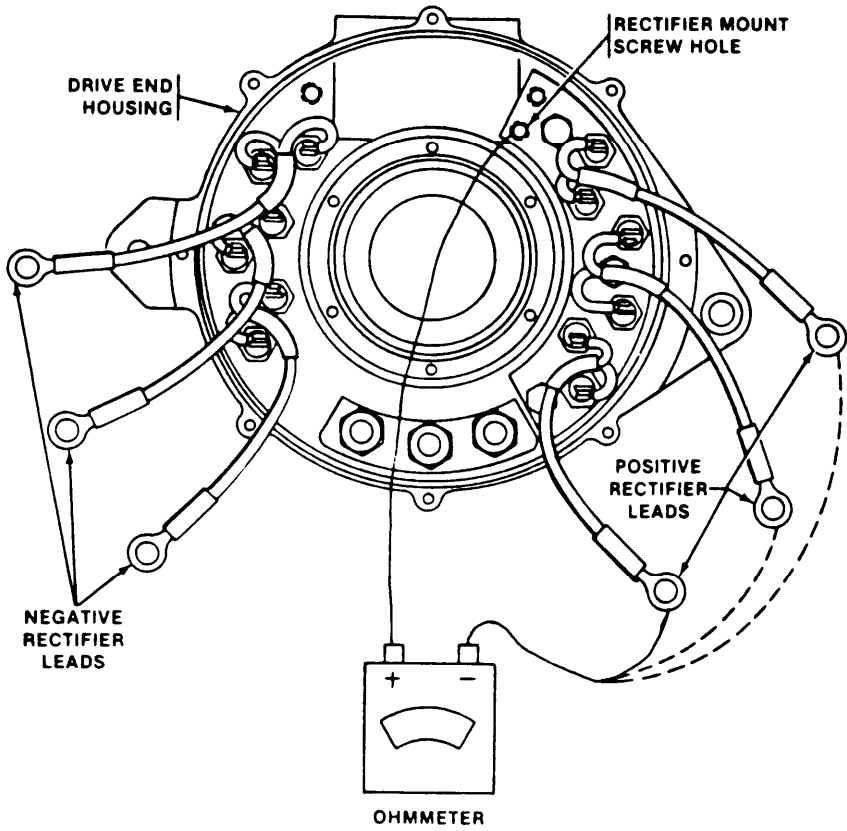

Figure 2-2. Shorted Positive Rectifier Test.

Step 4. Check for shorted positive rectifiers. Connect ohmmeter to each of the three positive rectifier leads in accordance with figure 2-2.

If the ohmmeter reading is less than 100,000 ohms, replace drive end housing assembly in accordance with paragraph 3-3, and go to step 8.

Table 2-1. Generator Troubleshooting - Continued

MALFUNCTION	TEST OR INSPECTION	CORRECTIVE ACTION
-------------	--------------------	-------------------

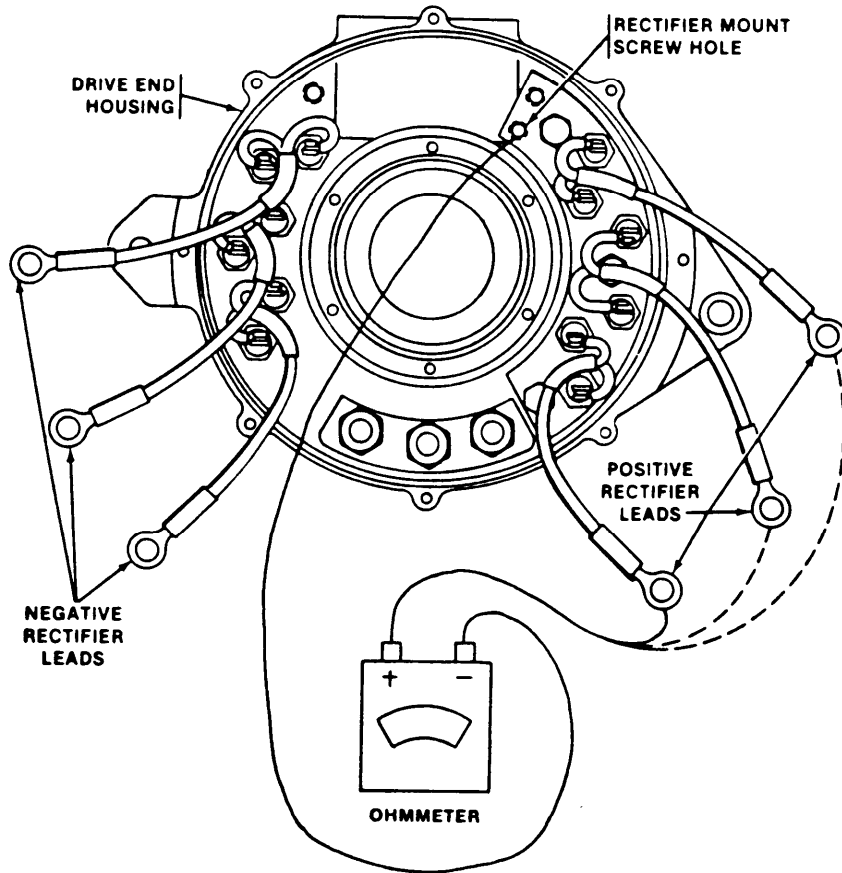

Figure 2-3. Open Positive Rectifier Test.

Step 5. Check for open positive rectifiers. Connect ohmmeter to each of the three positive rectifier leads in accordance with figure 2-3.

If the ohmmeter reading is more than 100 ohms, replace drive end housing assembly in accordance with paragraph 3-3, and go to step 8.

Table 2-1. Generator Troubleshooting - Continued

MALFUNCTION	TEST OR INSPECTION	CORRECTIVE ACTION
-------------	--------------------	-------------------

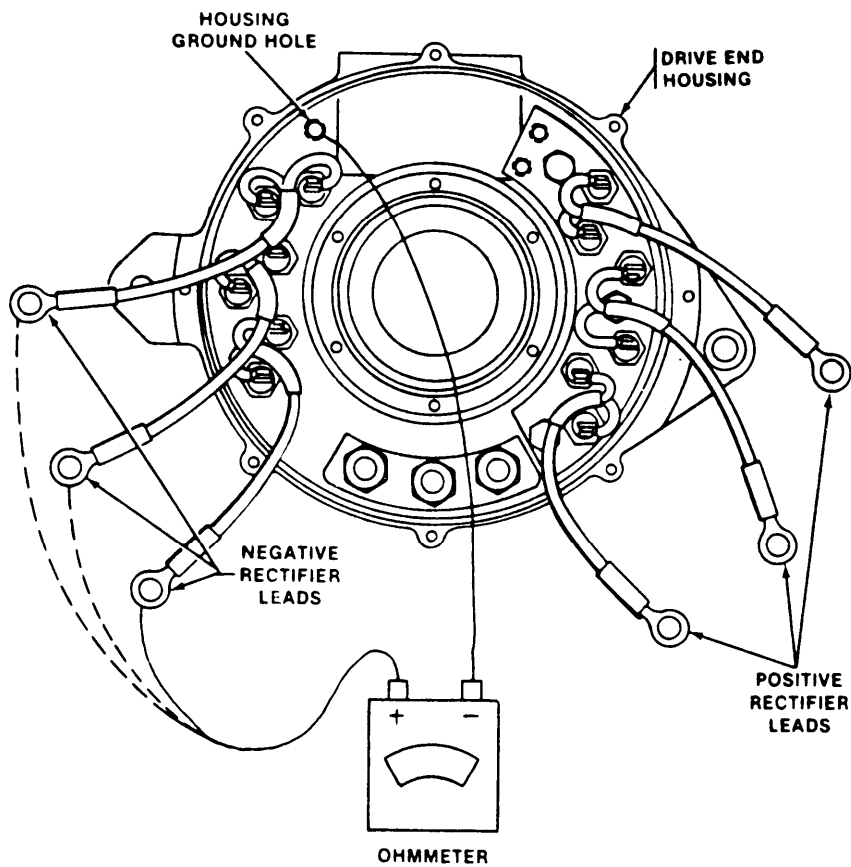

Figure 2-4. Shorted Negative Rectifier Test.

Step 6. Check for shorted negative rectifiers. Connect ohmmeter to each of the three negative rectifier leads in accordance with figure 2-4.

If the ohmmeter reading is less than 100,000 ohms, replace drive end housing assembly in accordance with paragraph 3-3, and go to step 8.

Table 2-1. Generator Troubleshooting - continued

MALFUNCTION	TEST OR INSPECTION	CORRECTIVE ACTION
-------------	--------------------	-------------------

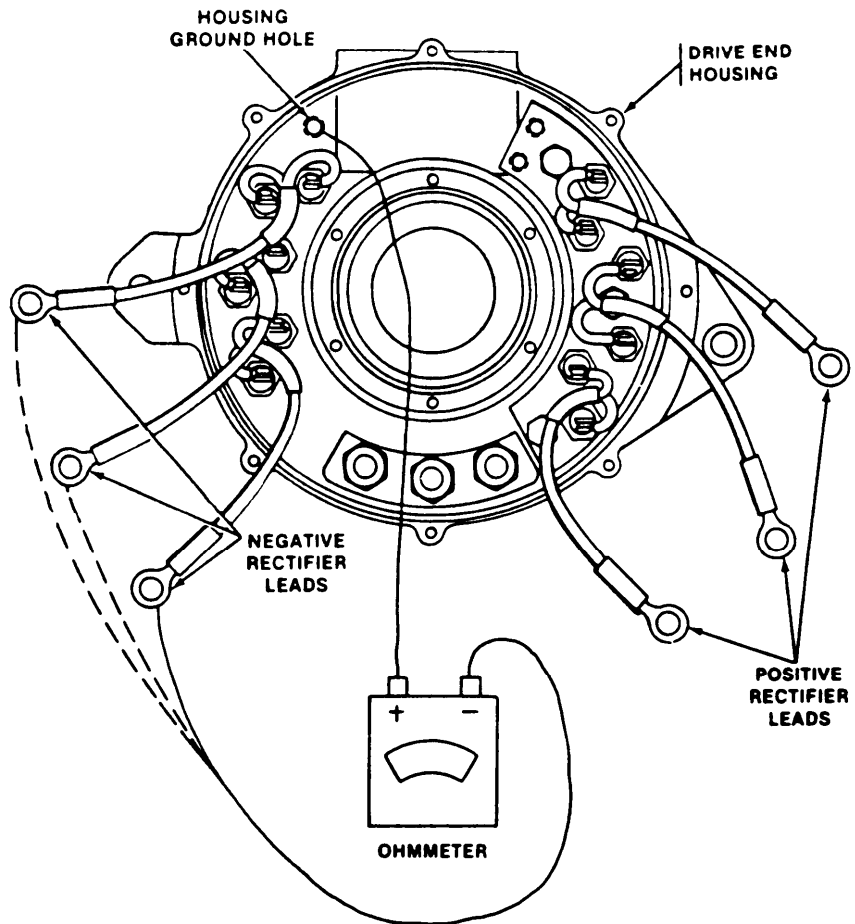

Figure 2-5. Open Negative Rectifier Test.

Step 7. Check for open negative rectifiers. Connect ohmmeter to each of the three negative rectifier leads in accordance with figure 2-5.

If the ohmmeter reading is more than 100 ohms, replace drive end housing assembly in accordance with paragraph 3-3, and go to step 8.

Table 2-1. Generator Troubleshooting - Continued

MALFUNCTION	TEST OR INSPECTION	CORRECTIVE ACTION
-------------	--------------------	-------------------

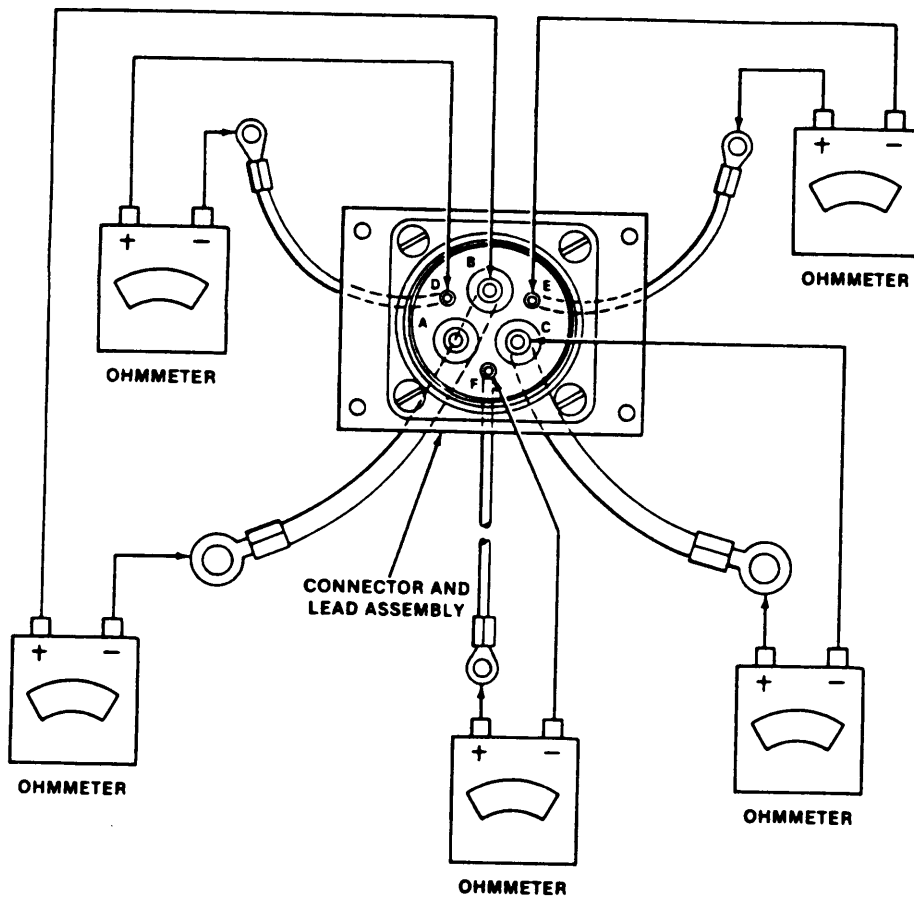

Figure 2-6. Connector Pin and Lead Continuity Check.

Step 8. Check continuity of pins and leads in connector assembly according to figure 2-6.

If the ohmmeter readings are greater than 0, connector assembly is defective. Replace connector assembly in accordance with paragraph 3-3 and go to step 9.

Table 2-1. Generator Troubleshooting - Continued

MALFUNCTION	TEST OR INSPECTION	CORRECTIVE ACTION
-------------	--------------------	-------------------

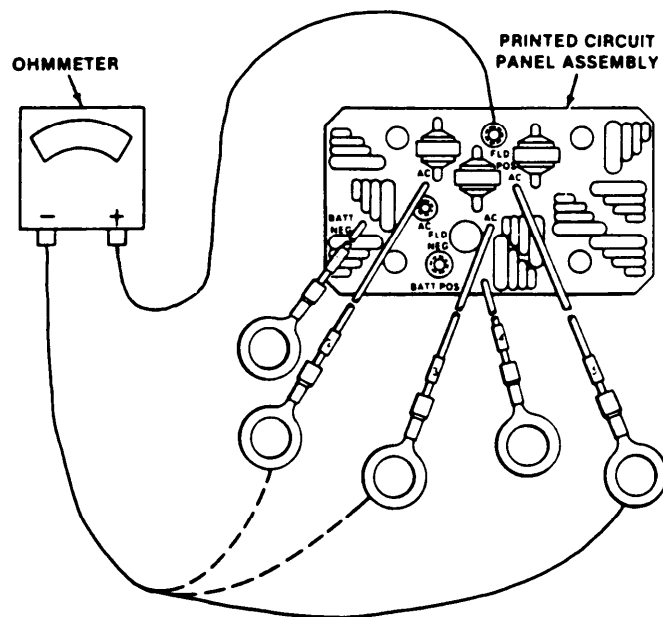

Figure 2-7. Shorted Printed Circuit Panel Assembly Diode Check.

Step 9. Check for shorted diodes on printed circuit panel assembly. Connect ohmmeter to each of the three long black leads according to figure 2-7.

If ohmmeter reading is less than 100 ohms, replace printed circuit panel assembly in accordance with paragraph 3-3 and go to step 13.

Table 2-1. Generator Troubleshooting - Continued

MALFUNCTION	TEST OR INSPECTION	CORRECTIVE ACTION
-------------	--------------------	-------------------

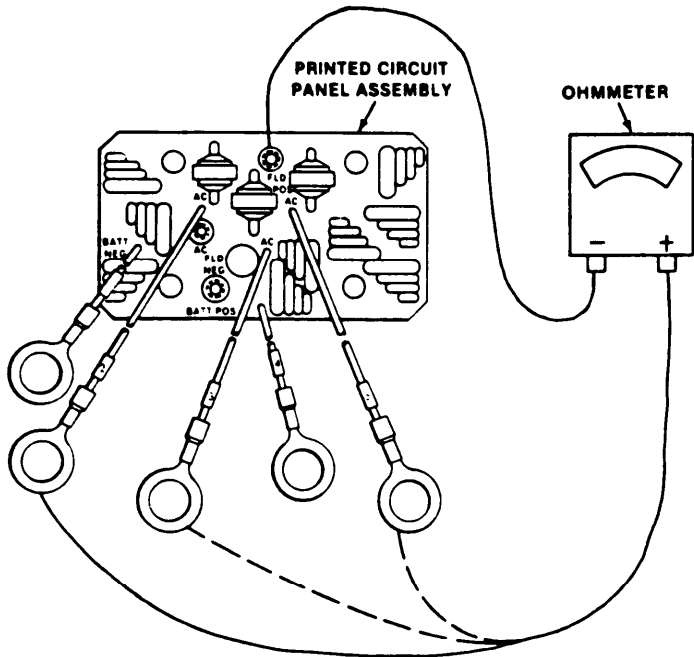

Figure 2-8. Open Printed Circuit Panel Assembly Diode Check.

Step 10. Check for open diodes on printed circuit panel assembly. Connect ohmmeter to each of the three long black leads according to figure 2-8.

If ohmmeter reading is higher than 100,000 ohms, replace printed circuit panel assembly in accordance with paragraph 3-3 and go to step 13.

Table 2-1. Generator Troubleshooting - Continued

MALFUNCTION	TEST OR INSPECTION	CORRECTIVE ACTION
-------------	--------------------	-------------------

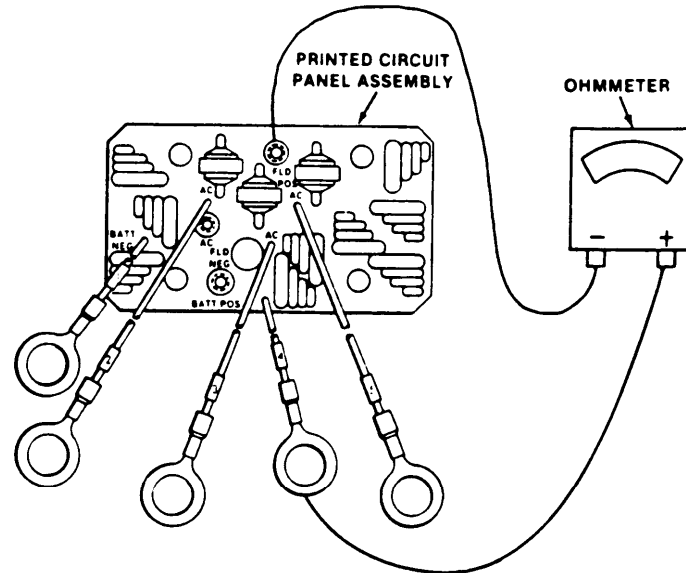

Figure 2-9. Shorted Printed Circuit Panel Assembly Capacitor Check.

- Step 11. Check for shorted or high leakage capacitors between battery positive and field positive according to figure 2-9.

NOTE

Ohmmeter may deflect to low resistance reading momentarily and then climb to a high resistance reading. This is normal when checking capacitors. The final ohmmeter reading is to be used in this test.

If ohmmeter reading is less than 100,000 ohms, capacitors are shorted. Replace printed circuit panel assembly in accordance with paragraph 3-3 and go to step 13.

Table 2-1. Generator Troubleshooting - Continued

MALFUNCTION	TEST OR INSPECTION	CORRECTIVE ACTION
-------------	--------------------	-------------------

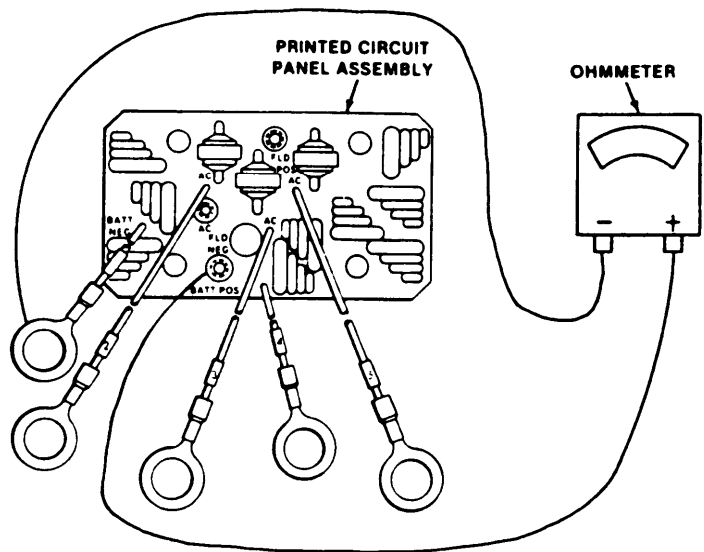

Figure 2-10. Shorted Printed Circuit Panel Assembly Capacitor Check.

- Step 12. Check for shorted or high leakage capacitors between field negative and ground according to figure 2-10.

NOTE

Ohmmeter may deflect to low resistance reading momentarily and then climb to a high resistance reading. This is normal when checking capacitors. The final ohmmeter reading is to be used in this test.

If ohmmeter reading is less than 100,000 ohms, capacitors are shorted. Replace printed circuit panel assembly in accordance with paragraph 3-3 and go to step 13.

Table 2-1. Generator Troubleshooting - Continued

MALFUNCTION	TEST OR INSPECTION	CORRECTIVE ACTION
-------------	--------------------	-------------------

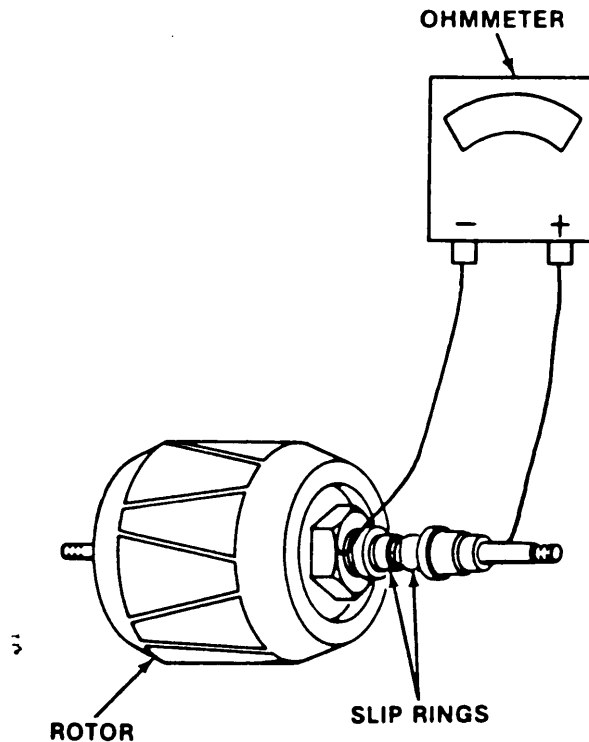

Figure 2-11. Rotor Ground Test.

- Step 13. Remove fan, anti-drive end housing, and rotor in accordance with paragraph 3-3b.
- Step 14. Check for grounded rotor field circuit according to figure 2-11.

If ohmmeter reading is less than 50,000 ohms, the rotor is grounded. Replace rotor and reassemble generator in accordance with paragraph 3-3.

If ohmmeter reading is greater than 50,000 ohms, rotor is not grounded. Go to step 15.

Table 2-1. Generator Troubleshooting - Continued

MALFUNCTION	TEST OR INSPECTION	CORRECTIVE ACTION
-------------	--------------------	-------------------

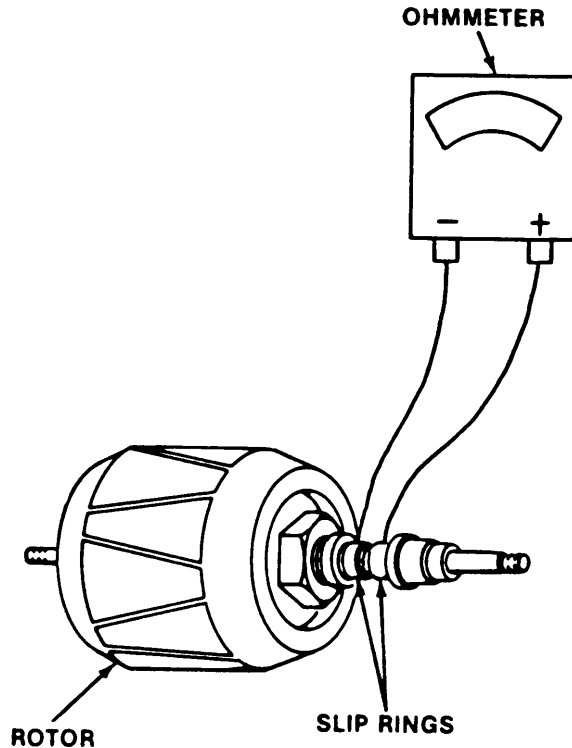

Figure 2-12. Rotor Resistance Test.

Step 15. Check resistance of rotor field circuit according to figure 2-12.

If ohmmeter reading falls outside 4.5-6.5 ohms, rotor is defective. Replace rotor, reassemble generator in accordance with paragraph 3-3, and go to step 16.

NOTE

Replace stator only if all previous checks indicate that all generator components were not defective.

If ohmmeter reading is between 4.5-6.5 ohms, rotor is not defective. Replace stator, reassemble generator in accordance with paragraph 3-1, and go to step 16.

Table 2-1. Generator Troubleshooting

MALFUNCTION	TEST OR INSPECTION	CORRECTIVE ACTION
-------------	--------------------	-------------------

Step 16. Test performance of generator in accordance with Appendix E.

If generator performance is in accordance with Appendix E, generator is not defective.

If generator performance is not in accordance with Appendix E, stator is defective. Disassemble generator and replace stator in accordance with paragraph 3-3. Reassemble generator, and repeat step 16.

Section III. PN N1205 AND N1206 (Niehofl)

2-4. ON VEHICLE TEST

a. After the generator has been received by direct support maintenance personnel for preliminary inspection, before being installed on the engine, or if performance of the generator has been unsatisfactory due to unknown causes, you must inspect as described in this section.

2-5. TEST SET-UP

a. Refer to vehicle manuals and discharge batteries as follows:

- (1) Turn fuel off.
- (2) Turn lights and accessories on.
- (3) Crank engine for 10-15 seconds to discharge batteries.
- (4) Turn lights and accessories off.
- (5) Turn fuel on.

b. Determine factory setting of regulator and normal range of regulated voltage (Table 2-2).

Table 2-2. Voltage Regulator Specifications

GENERATOR (REGULATOR)	SYSTEM VOLTAGE	FACTORY SETTING	NORMAL RANGE
N1205/N1206	24	28.0	26.0 TO 30.0

c. Attach multimeter as indicated in Figure 2-13. If an in-line multimeter is used, disconnect battery ground cable before connecting multimeter. Then reconnect battery ground cable. Multimeter connections must carry rated output of generator.

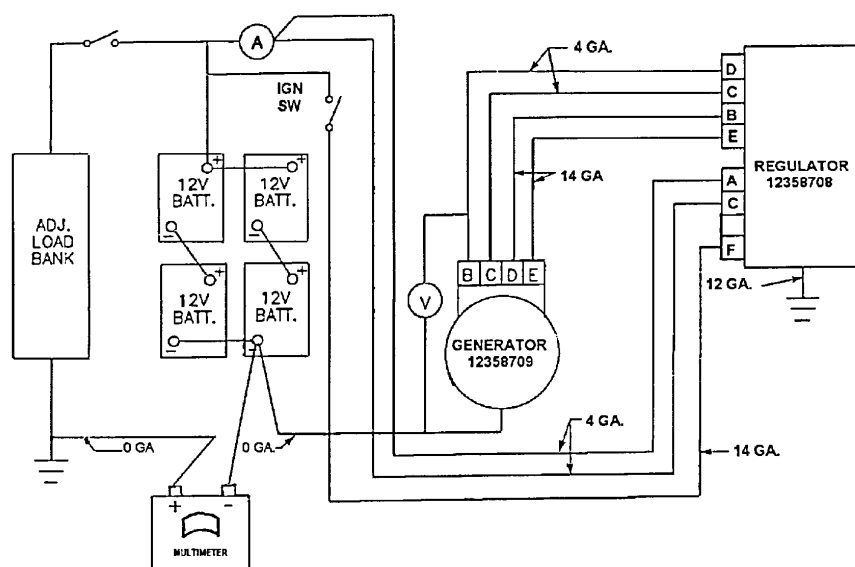

Figure 2-13. Charging System Schematic

2-6. GENERAL TEST PROCEDURES

CAUTION

If voltmeter reading exceeds 30.5 volts for 24 volt systems, STOP engine immediately and refer to Table 2-3.

a. Start engine and accelerate to high idle. Refer to TM 9-2350- 261-10, or TM 9-2350-277-10, or TM 9-2350-247-10 Operator TM's.

b. Observe ammeter and voltmeter readings on multimeter. If battery is sufficiently discharged, amps should be "high" within +1- 10% of output specified by performance curve (generator RPM = engine idle RPM X pulley ratio). Volts should be within or below the "normal range" of Table 2-2. As battery approaches full charge, amps should fall as volts rise. When amps and volts stabilize, note readings and refer to Table 2-3.

Table 2-3. TROUBLESHOOTING DIAGNOSIS

AMPS	VOLTS	DIAGNOSIS
HIGH	LOW	CHARGING SYSTEM GOOD. BATTERY NOT FULLY CHARGED. WAIT FOR CHARGING SYSTEM TO BRING BATTERY TO FULL CHARGE. AMPS SHOULD FALL AND VOLTS SHOULD STABILIZE WITHIN NORMAL RANGE PER TABLE 2-2.
HIGH	NORMAL	NOTE IF AMPS FALL OR VOLTS EXCEED NORMAL RANGE PER TABLE 2-2. IF AMPS FALL AND VOLTS REMAIN NORMAL, CHARGING SYSTEM IS GOOD. IF VOLTS EXCEED NORMAL, REGULATOR AND/OR FIELD COIL SHOULD BE REPLACED. GO TO STATIC TESTS.
HIGH	HIGH	STOP TEST. REGULATOR AND /OR FIELD COIL SHOULD BE REPLACED. GO TO STATIC TESTS.
LOW	LOW	IF BOTH AMPS AND VOLTS ARE LOW, CHECK TO BE SURE MULTIMETER LEADS ARE PROPERLY ATTACHED. IF OKAY, REPLACE EITHER GENERATOR OR REGULATOR. REFER TO GENERATOR AND REGULATOR TEST PROCEDURE.
LOW	NORMAL	CHARGING SYSTEM GOOD.
LOW	HIGH	STOP TEST. IF BATTERY AND VOLTMETER ARE BOTH GOOD, REPLACE REGULATOR AND/OR FIELD COIL.

c. Discover the cause for failure then disassemble and repair the generator before proceeding with prescribed tests. Performing additional operational tests on a damaged generator will only increase the damage.

2-7. DYNAMIC BENCH TEST PROCEDURES

a. Confirm results of On-Vehicle test by these bench tests if possible. When it is not possible to perform On-Vehicle tests, check generator performance quickly by referring to these bench tests.

NOTE

Test bench must have a 20 Hp motor or larger, capable of driving the generator to 7000 RPM, a multimeter (App D, Item 3) with 0-400 amp range, and 0-40 volt range.

b. Mount generator on test bench according to the bench manufacturer's instructions. Refer to Figure 2-13 for set-up to measure voltage and amperage produced by generator. For bench tests, voltage is normal when it is within the normal range of Table 2-2, and amperage is high when it is within +/- 10 % of rated output (output 5000 RPM).

c. Run the No-Load Test without electrical load, but with batteries connected. Run generator at 5000 RPM and refer to Table 2-4.

Table 2-4. NO-LOAD TEST DIAGNOSIS

AMPS	VOLTS	DIAGNOSIS
HIGH	LOW	TEST BENCH BATTERY DISCHARGED OF DEFECTIVE. ALLOW TO CHARGE OR REPLACE.
HIGH	NORMAL	ALLOW TIME TO STABILIZE WHILE MONITORING VOLTS. IF VOLTS RISE ABOVE NORMAL RANGE (25V-31V), REGULATOR AND/OR FIELD COIL MUST BE REPLACED. IF AMPS FALL, CHARGING SYSTEM IS OKAY.
HIGH	HIGH	STOP TEST. REGULATOR AND /OR FIELD COIL MUST BE REPLACED. GO TO STATIC TESTS
LOW	LOW	GENERATOR AND/OR REGULATOR MUST BE REPAIRED OR REPLACED.
LOW	NORMAL	REGULATOR IS GOOD, GO TO FULL-LOAD TEST.
LOW	HIGH	STOP TEST. BENCH MALFUNCTION OR WIRING ERROR.

- d. Run the full-load Test at 5000 RPM. Increase load to the rated output +/- 10% and refer to Table 2-5.

Table 2-5. FULL-LOAD TEST DIAGNOSIS

AMPS	VOLTS	DIAGNOSIS
HIGH	LOW	TEST BENCH BATTERY DISCHARGED OR DEFECTIVE. ALLOW TO CHARGE OR REPLACE.
HIGH	NORMAL	CHARGING SYSTEM OKAY.
HIGH	HIGH	STOP TEST. REGULATOR AND /OR FIELD COIL MUST BE REPLACED. GO TO STATIC TESTS.
LOW	LOW	GENERATOR AND/OR REGULATOR MUST BE REPAIRED OR REPLACED.
LOW	NORMAL	INCREASE LOAD
LOW	HIGH	STOP TEST. BENCH MALFUNCTION OR WIRING ERROR.

2-8. STATIC TEST PROCEDURES

- a. Perform static tests on the partially disassembled generator to confirm component failure indicated by On-Vehicle test and bench tests.
- b. Complete all static tests before repairing and assembling the generator.
- c. Remove pulley and rear housing to perform the following checks in accordance with paragraph 3-4b, steps 1 thru 6.
- d. Refer to ohmmeter readings on multimeter.
- e. Static Checks:
 - (1) Output Transistor - Do not check output transistor. If dynamic test indicates regulator or field coil failure and field coil is good, replace the regulator. (refer to step 3, field coil)
 - (2) Clamping Diode - [1] Set ohmmeter to X100 scale and make sure ohmmeter is zeroed. [2] Disconnect the regulator. [3] Connect one multimeter lead to pin E. [4] Connect the other lead to pin B and observe ohmmeter reading. In one direction the ohmmeter should read less than 600 ohms, in the other direction the ohmmeter should read very high. If ohmmeter reads less than 600 ohms in both directions (short) or very high in both directions (open) clamping diode is defective and regulator must be replaced.

NOTE

If regulator malfunction is indicated, field coil failure must also be suspected.

(3) Field Coil

(a) Disconnect both field coil leads F+ and F- from front housing (fig 2-14).

(b) Open field coil - Set ohmmeter to X1 scale and make sure ohmmeter is zeroed. Measure resistance between field leads (+F and -F). Ohm reading should read less than 4 ohms. If ohms read 4 ohms or more, the field coil is open and must be corrected by replacing or repairing stator and shell assembly, in accordance with paragraph 3-4b, steps 1 thru 8.

(c) Grounded field coil - Set ohmmeter to X10k scale and make sure ohmmeter is zeroed. Connect one multimeter lead to either field lead (F+ or F-). Connect the other multimeter lead to the front housing ground stud. The ohm reading should be very high. If the ohms read less than 100K ohms, the field coil is grounded and must be corrected by replacing or repairing stator and shell assembly, in accordance with paragraph 3-4b, steps 1 thru 8.

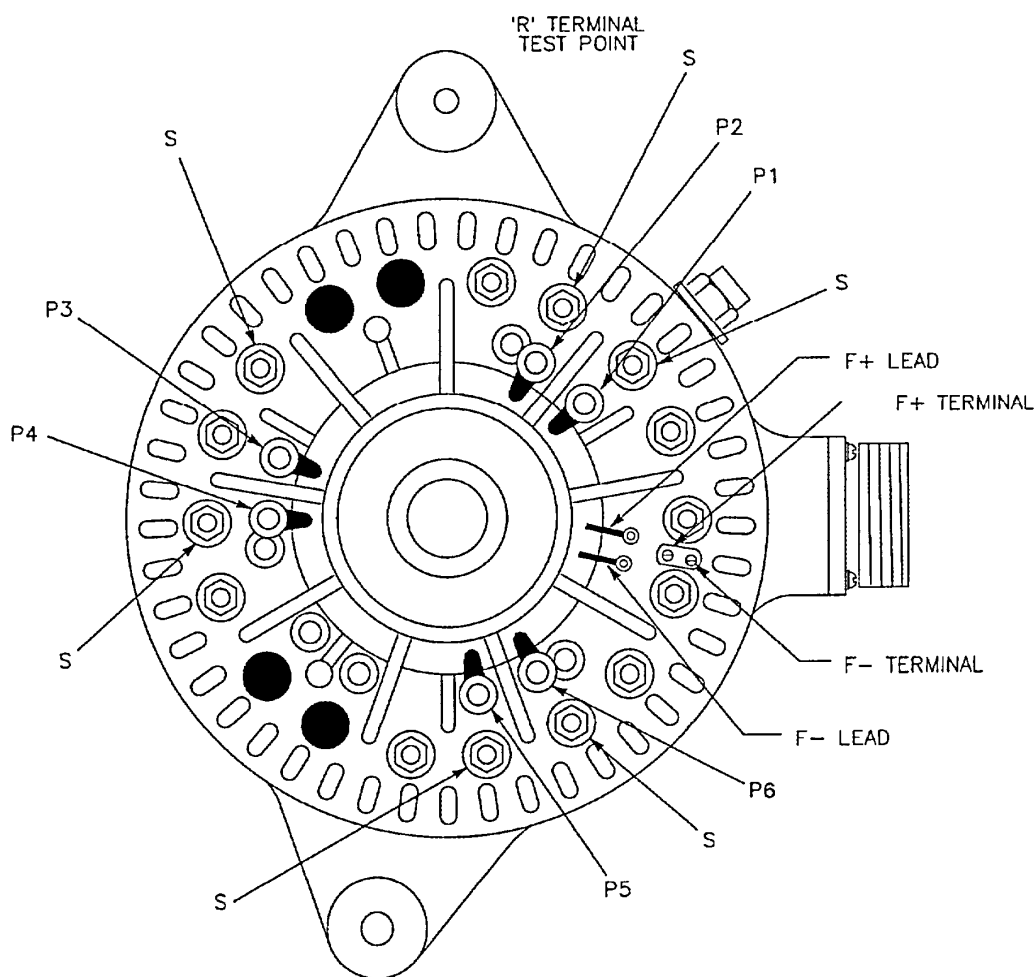

Figure 2-14. Front Housing Connections

(4) Electrical Continuity Check - Set ohmmeter to X10 scale and make sure ohmmeter is zeroed. Check the generator connector pins to insure all internal wiring is intact. Check output plug continuity (refer to table 2-6). If any reading is out of limits, replace generator front housing, in accordance with paragraph 3-4b, steps 1 thru 17.

Table 2-6. OUTPUT PLUG CONTINUITY

Ohmmeter Scale	Generator Output Plug		Expected Readings
X 10K	PIN B	GND *	Very High
X 1	PIN B	PIN C	ZERO
X 1	PIN B	PIN D	Very High
X 10K	PIN E	GND *	Very High

*** GND connections are made to ground terminal located on the outside of front housing.**

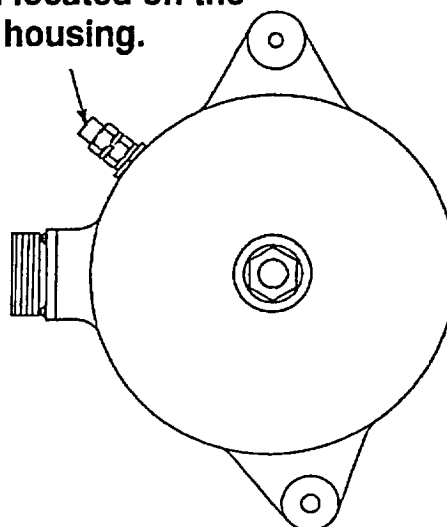

(5) Diode heat sink tests - Remove all phase leads (P1-P6) from front housing (fig 2-14). Check the diode heat sink assembly using a diode tester. If diode tester is used, refer to manufacturers' instructions for proper connections. If a diode tester is not available, use a multimeter and the following procedures.

CAUTION

To prevent damage to the diodes, do not use an AC device, such as a leakage tester to check the diode heat sink.

NOTE

Do not allow sleeves on leads to slide down leads. Phase terminals without sleeves can short to alternator body.

NOTE

Heat sink diodes are de-rated for heavy duty performance. If diode failure is detected, examine the entire charging system for loose connections. If a diode failure is indicated, suspect stator failure as well.

(a) Positive diodes -

[1] Set ohmmeter to X100 scale and make sure ohmmeter is zeroed. Connect one lead of the multimeter to pin B or C of the output connector. Connect the other lead to each of the six heat sink phase terminals S (fig. 2-15). All six readings should be nearly alike; either less than 600 ohms or very high. If all six readings are not alike, the diode rectifier assembly is defective. Replace heat sink assembly or front housing assembly, in accordance with paragraph 3-4b, steps 1 thru 17.

[2] Reverse phase leads, and observe resistance between pin B or C of the output connector and each of the six heat sink terminals S (fig. 2-15). All six readings should be nearly alike, but opposite the readings obtained previously; if all readings were less than 600 ohms before, all readings should be very high now and vice versa. If any readings is not alike, the diode rectifier is defective, replace heat sink assembly, in accordance with paragraph 3-4b, steps 1 thru 17.

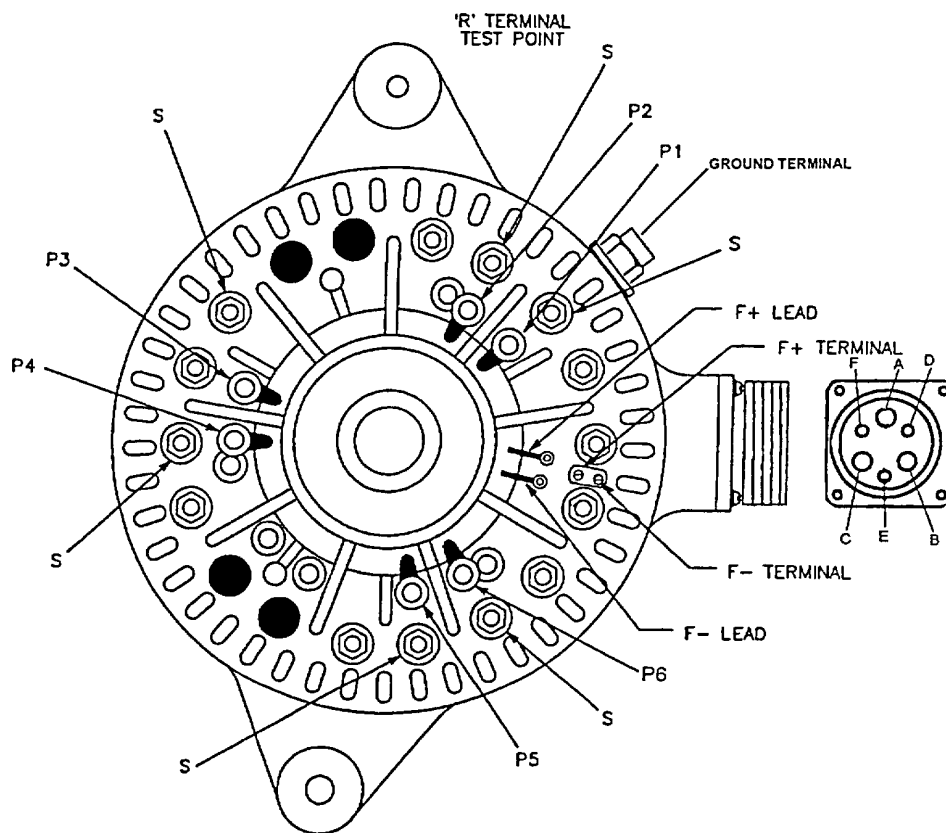

Figure 2-15. Diode Testing Points

(b) Negative Positive diodes -

[1] Set ohmmeter to X100 scale and make sure ohmmeter is zeroed. Connect one lead of the multimeter to the ground terminal on the outside of the front housing and connect the other lead to each of the six heat sink phase terminals S (fig. 2-15). All six readings should be nearly alike and read very high. If all six readings are not alike, the diode rectifier assembly is defective. Replace the front housing assembly, in accordance with paragraph 3-4b, steps 1 thru 17.

[2] Reverse phase leads, and observe resistance between pin B or C of the output connector and each of the six heat sink terminals S (fig. 2-15). All six readings should be very high. If all six readings are not alike, the diode rectifier assembly is defective. Replace the front housing assembly, in accordance with paragraph 3-4b, steps 1 thru 17.

(6) Stator Tests - Remove all phase leads (P1-P6) from front housing (fig 2-16).

NOTE

A grounded stator is difficult to confirm by static check. Examine stator for burnt insulation or loose coil.

NOTE

It may be necessary to probe under the sleeves of the phase leads to make electrical contact.

(a) Open stator winding - Set ohmmeter for X10 scale and make sure ohmmeter is zeroed. Connect multimeter leads to each successive pair of phase stator windings (fig. 2-16). Ohms should read less than 1 ohm between each pair of stator phase windings. If ohms reads very high, the stator is open and must be replaced. Replace or repair stator and shell assembly, in accordance with paragraph 3-4b, steps 1 thru 12.

(b) Shorted stator winding - Set ohmmeter for X1 scale and make sure ohmmeter is zeroed. Connect multimeter leads to each phase lead and ground terminal located on outside of front housing (fig. 2-16). Ohms should read very high. If ohms read zero, the stator is grounded and must be replaced. Replace or repair stator and shell assembly, in accordance with paragraph 3-4b, steps 1 thru 12.

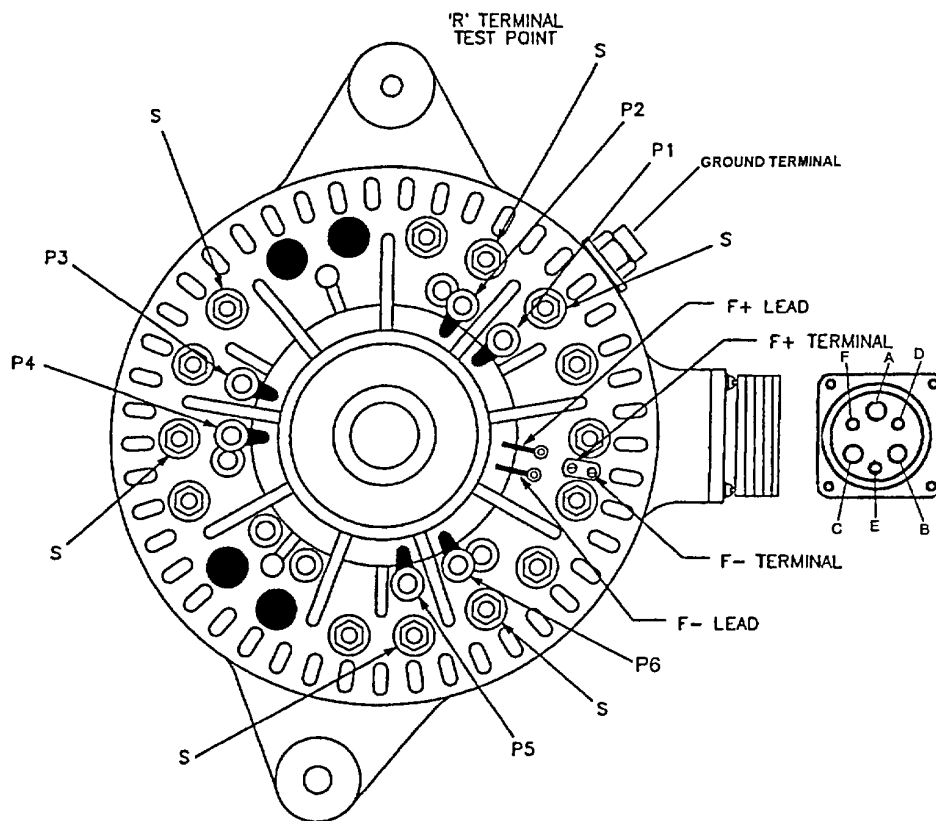

Figure 2-16. Stator Winding Points

CHAPTER 3**GENERATOR MAINTENANCE****Section I. PN 2260AC AND A0012266AA****3-1. CONSTRUCTION**

The generator is a belt driven, air-cooled device used for producing the necessary direct current to charge the vehicle and equipment batteries. The generator consists of a drive housing, stator, rotor, anti-drive end housing, and cooling fan. The drive end housing contains positive and negative rectifiers, brushes, seals, and bearings.

3-2. GENERAL INSTRUCTIONS

a. The procedures discussed in this section cover complete disassembly of the generator.

b. In cases where the generator does not require complete disassembly, disassemble only to the point required to inspect, clean, and replace the damaged component.

3-3. GENERATOR REPAIR INSTRUCTIONS

a. Generator Cleaning Procedures.

(1.) Clean exterior surfaces of generator as follows:



- App B).
- (a) Clean exterior surface of generator with cloth (item 5, App B) dipped in dry cleaning solvent (item 2,
 - (b) Dry thoroughly with compressed air or dry cloth (item 5, App B).

NOTE

Compressed air must not exceed 10 psig.

- (2) If necessary, clean rotor slip rings as follows:

- 1, App B).
- (a) Remove dirt or carbon brush film from rotor slip rings using a 1/2 inch wide strip of crocus cloth (item

WARNING

Eye injury can occur if eye shields are not worn when using Compressed air to blow dirt or other particles off rotor slip rings.

- (b) After sanding, blow dirt or other particles off rotor slip rings using compressed air.

- b. Generator Disassembly procedure.

- (1) Remove fan (fig. 3-1).

CAUTION

When removing self-locking nut, do not attempt to keep generator shaft from turning by inserting screwdriver or any other tool between fan blades. To do so could result in damage to fan.

- (a) Ensure that woodruff key is in key slot on pulley end of shaft. Clamp key and shaft securely in a vise with soft-jaw caps to prevent generator shaft from turning.
- (b) Remove and discard self-locking nut (1).
- (c) Remove fan (2) and key (3) from shaft of rotor (14).
- (d) Remove generator from vise.

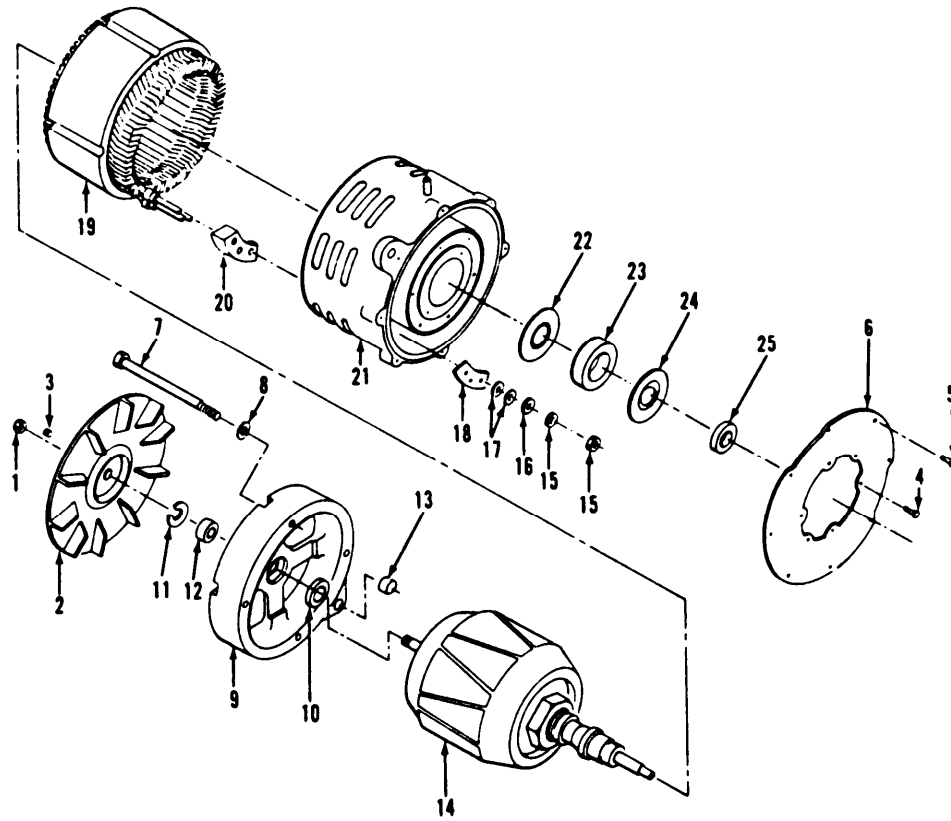

Legend:

- | | |
|--------------------------|-------------------------------|
| 1 Self-locking nut | 13 Slideable bushing |
| 2 Fan | 14 Rotor |
| 3 Key | 15 Nut (6) |
| 4 Screw (6) | 16 Washer (3) |
| 5 Screw (8) | 17 Washer (6) |
| 6 Cover plate | 18 Insulator |
| 7 Screw (4) | 19 Stator |
| 8 Lock washer (4) | 20 Insulator |
| 9 Anti-drive end housing | 21 Drive end housing assembly |
| 10 Inside seal | 22 Inside seal |
| 11 Outer seal | 23 Ball bearing |
| 12 Roller bearing | 24 Outer seal |
| | 25 Spacer |

Figure 3-1. Generator.

(2) Remove cover plate (fig. 3-1).

NOTE

Scribe cover plate and drive end housing assembly before removing cover plate.

(a) Remove six screws (4) and eight screws (5) securing cover plate (6) to drive end housing assembly (21).

(b) Remove cover plate (6).

(3) Remove connector assembly and mounting plate (fig. 3-2).

(a) Remove two brass bolts (1) securing two heavy black connector leads and thin red lead to positive rectifier heat sink.

(b) Remove four screws (2) and lock washers (3) securing connector assembly (4) and mounting plate (5) to drive end housing assembly (6). Move connector assembly and mounting plate to expose printed circuit panel assembly (7).

(c) Remove three screws (8) and three lock washers (9) securing three thin black connector leads and two thin black brush leads to printed circuit panel assembly (7).

(d) Remove connector assembly (4) and mounting plate (5) from drive end housing assembly (6). Scribe mounting plate and drive end housing assembly.

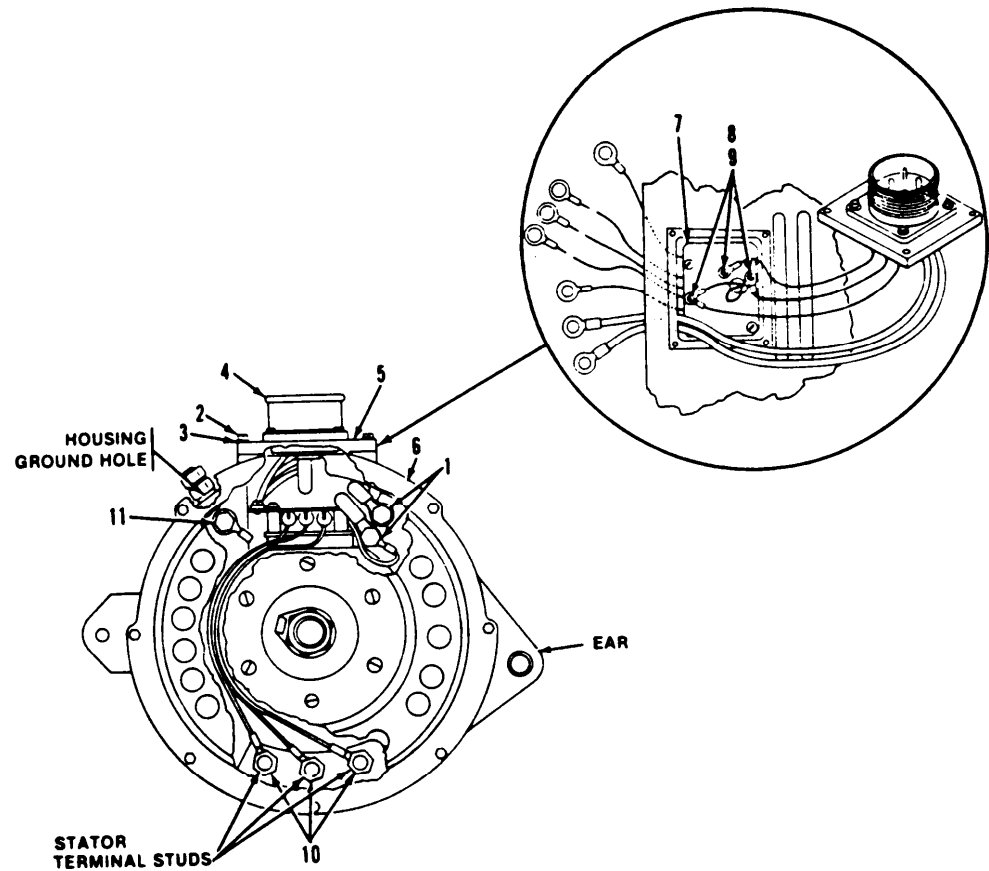

Legend:

- | | |
|----------------------|----------------------------------|
| 1 Brass bolt (2) | 6 Drive end housing assembly |
| 2 Screw (4) | 7 Printed circuit panel assembly |
| 3 Lock washer (4) | 8 Screw (3) |
| 4 Connector assembly | 9 Lock washer (4) |
| 5 Mounting plate | 10 Nut (3) |
| | 11 Screw |

Figure 3-2. Connector Assembly.

(4) Remove printed circuit panel assembly, brush assemblies, and brush holder (fig. 3-3).

(a) Remove three nuts (10, fig. 3-2) securing three long black leads from printed circuit panel assembly (7, fig. 3-2) to three stator terminal studs.

(b) Remove screw (11, fig. 3-2) securing short black lead from printed circuit panel assembly (7, fig 3-2) to housing ground hole.

(c) Remove four screws (1), lock washers (2), washers (3), and insulation washers (4) securing printed circuit panel assembly (5) to drive end housing (6).

CAUTION

Brush holder can be damaged if not handled carefully. Handle brush holder carefully.

(d) Remove printed circuit panel assembly (5), four spacers (7), brush cover (8), two brush assemblies (9), and brush holder (10) from drive end housing assembly (6). If brush holder binds to drive end housing, tap brush holder with plastic mallet.

(5) Remove anti-drive end housing (fig. 3-1).

(a) Remove four screws (7) and lock washers (8) used to secure anti-drive end housing (9) and stator (19) to drive end housing assembly (21).

NOTE

If anti-drive end housing binds to stator, tap housing with plastic mallet.

(b) Remove anti-drive end housing (9) from shaft of rotor (14).

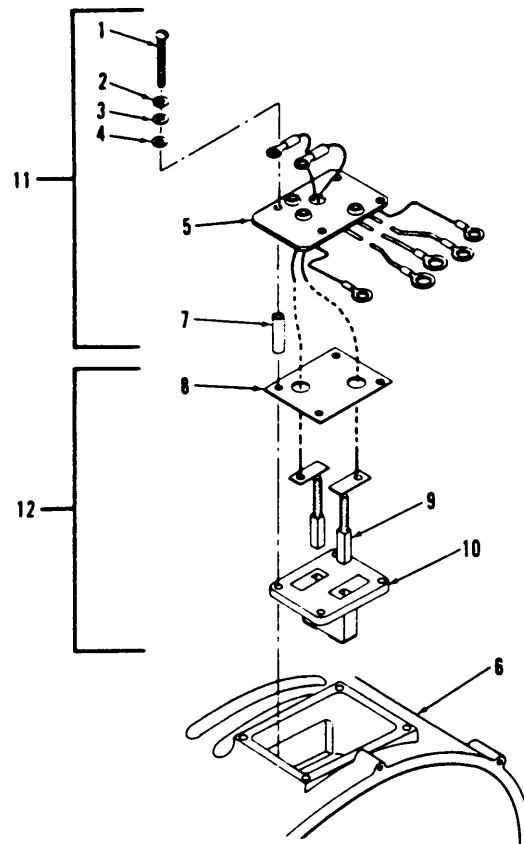

Legend:

- | | |
|----------------------------------|--|
| 1 Screw (4) | 6 Drive end housing assembly |
| 2 Lock washer (4) | 7 Spacer (4) |
| 3 Washer (4) | 8 Brush cover |
| 4 Insulation washer (4) | 9 Brush assembly (2) |
| 5 Printed circuit panel assembly | 10 Brush holder |
| | 11 Printed circuit panel assembly unit |
| | 12 Brush assembly unit |

Figure 3-3. Printed Circuit Panel Assembly and Brush Assembly.

(6) Remove inside seal, outer seal, roller bearing, and slideable bushing from anti-drive end housing (fig. 3-1).

(a) place anti-drive end housing (9) on workbench. Use a 3/8 inch punch to knock out inside seal (10) according to figure 3-4. Discard seal.

CAUTION

If anti-drive end housing is not flat when placed in arbor press, it can crack. Make sure that anti-drive end housing is placed flat. Guide pins must not rest on arbor press.

(b) Turn anti-drive end housing over, and place it in arbor press according to figure 3-5.

(c) Place roller bearing tool (fig. F-1) on roller bearing flange according to figure 3-5, and press out outer seal (11) and roller bearing (12) at the same time. Discard bearing and seal.

(d) Use a 1/2 inch diameter bolt to press out slideable bushing (13) while supporting housing ear.

(7) Remove rotor (14).

CAUTION

When handling stator, do not allow winding end turns to be placed on any hard surfaces. Failure to do this may result in damage to stator winding end turns.

(a) Place generator in arbor press with drive end housing assembly (21) facing up and supported on stator (19) housing outer edges.

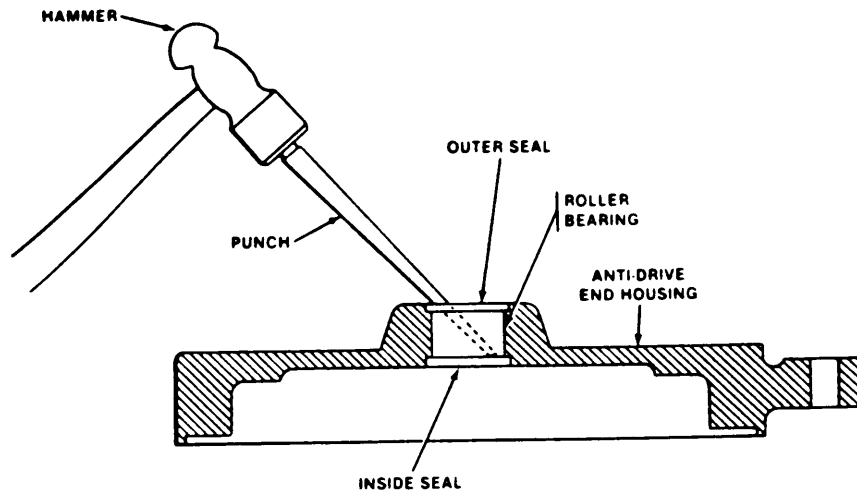

Figure 3-4. Inside Seal Removal from Anti-Drive End Housing.

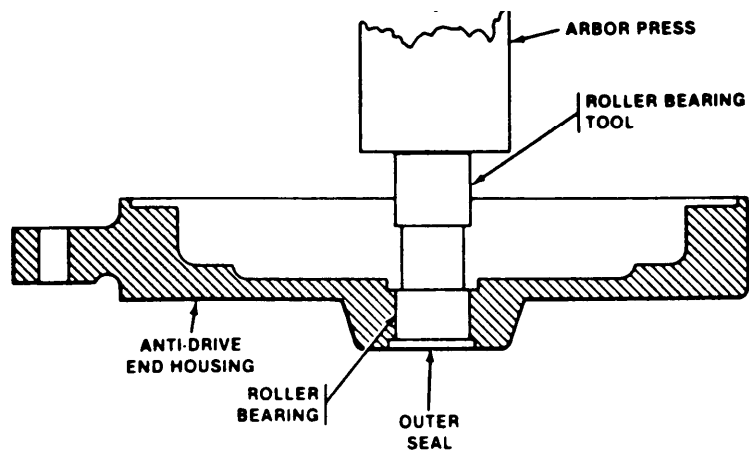

Figure 3-5. Roller Bearing and Outer Seal Removal from Anti-Drive End Housing.

WARNING

While the rotor is being pressed out of the drive end housing assembly, firmly grasp bottom section of rotor shaft to prevent rotor from dropping. Failure to do this could result in injury to personnel and damage to equipment.

(b) Apply pressure on top of rotor shaft to remove rotor (14) from drive end housing assembly (21).

(c) Remove spacer (25) from outer seal (24).

(8) Remove stator (fig. 3-1).

(a) Remove stator (19) and drive end housing assembly (21) from arbor press. Place assembly on top of anti-drive end housing (9) so that drive end housing assembly (21) faces up and stator laminations fit flush in pilot bore of anti-drive end housing to protect stator windings.

(b) Remove three rectifier leads from stator terminal studs, and bend leads out of the way to provide access to stator terminal nuts.

(c) Remove three nuts (15) used to secure rectifier leads to stator terminal studs.

(d) Remove three rectifier leads from stator terminal studs, and bend leads out of the way to provide access to terminal insulator (18).

(e) Remove three nuts (15), washers (16), and six spring washers (17) used to secure insulator (18) to stator terminal studs.

(f) Remove insulator (18) from stator terminal studs.

NOTE

To loosen stator terminal block insulator from inside of drive end housing, it may be necessary to tap on drive end housing in an upward direction using a plastic mallet.

(g) Remove drive end housing assembly (21) upward off stator (19) and terminal block insulator (20), and place on workbench with rectifiers facing upward.

(h) Remove terminal block insulator (20) from stator terminal studs.

(i) Remove stator (19) from anti-drive end housing (9), and place on workbench so that winding end turns are not in contact with workbench surface.

(9) Remove inside seal, ball bearing, and outer seal from drive end housing assembly (fig. 3-1).

CAUTION

Care must be taken to ensure that all rectifier leads are inside housing cavity. Failure to do so may result in damage to rectifier leads.

(a) Pack all rectifier leads down inside cavity in drive end housing assembly (21), and place housing in arbor press with rectifiers facing down.

(b) Place ball bearing tool (fig. F-1) on inside seal according to figure 3-6. Press out inside seal (22), ball bearing (23), and outer seal (24), all at the same time. Discard both seals and ball bearing.

c. Generator Inspection Procedure (fig. 3-1).

(1) Inspect drive end housing assembly (21) and anti-drive end housing (9) for cracks and broken parts. Apply electrical tests to drive end housing assembly in accordance with instructions in table 2-1.

(2) Inspect stator (19) for charred or damaged winding end turns.

(3) Inspect rotor (14) for loose slip rings and for dirt or carbon film on slip ring brush surfaces. Inspect for damaged threads on both ends of shaft. Apply electrical tests to rotor in accordance with instructions in table 2-1.

(4) Inspect brush holder (10, fig. 3-3) and two brush assemblies (9, fig. 3-3) for cracks and broken parts. Check brushes for wear length according to figure 3-7.

(5) Inspect the connector assembly (4, fig. 3-2) for loose pins in rubber grommet and for damaged connector threads. Apply electrical tests to connector assembly in accordance with instructions in table 2-1.

(6) Inspect fan (2) for cracks and broken parts.

(7) Inspect slideable bushing (13) for wear and tight fit in anti-drive end housing (9). Bushing should not move within housing with hand pressure.

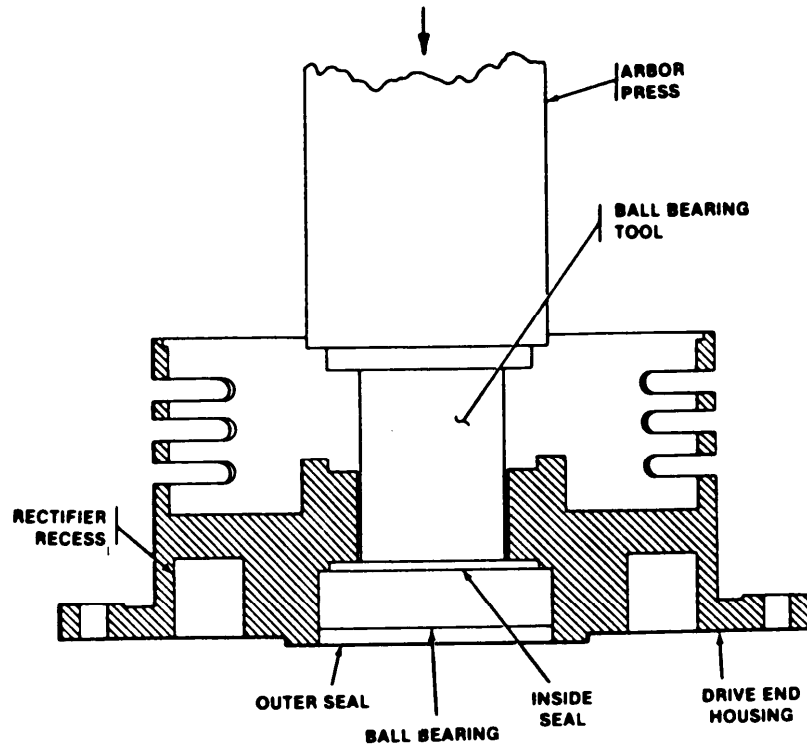

Figure 3-6. Inside Seal, Ball Bearing, and Outer Seal Removal from Drive-End Housing Assembly.

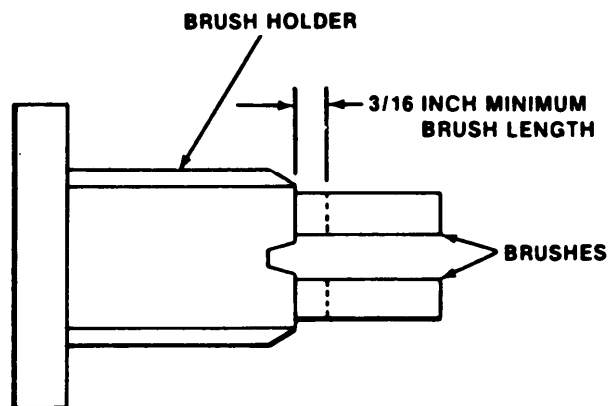

Figure 3-7. Brush Length Inspection.

d. Generator Repair Procedure. Replace unserviceable parts as required.

e. Generator Assembly Procedure.

(1) Upon reassembly, all parts disturbed during disassembly, except brushes and brush holder, must be coated with epoxy enamel (item 3, App B).

(2) Install inside seal to drive end housing assembly (fig. 3-1).

(a) Pack all rectifier leads down inside cavity in drive end housing assembly (21). Place housing in arbor press with rectifiers facing up.

CAUTION

Bearing will not seat properly if seal is not placed correctly. Place seal on seal bore with seal lips flaring up.

(b) Place inside seal (22) in position on seal bore with seal lips flaring up . See figure 3-8 for proper seal lip position.

(c) Place ball bearing tool (fig. F-1) on top of inside seal (22) according to figure 3-9. Press in seal flush with bottom of bearing bore.

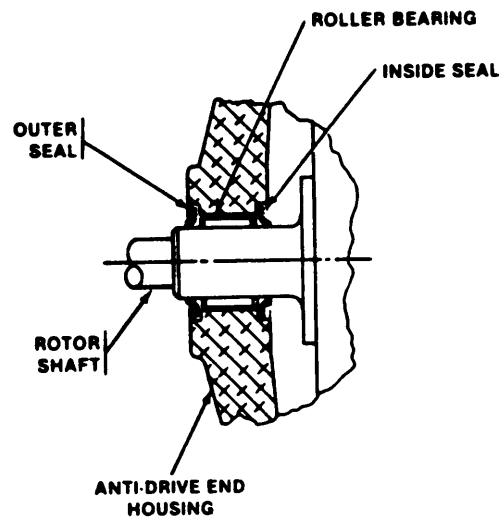
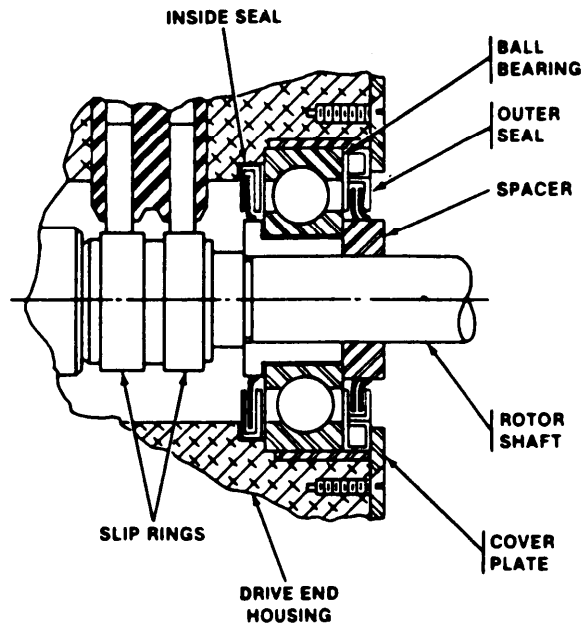

Figure 3-8. Proper Seal Lip Positions.

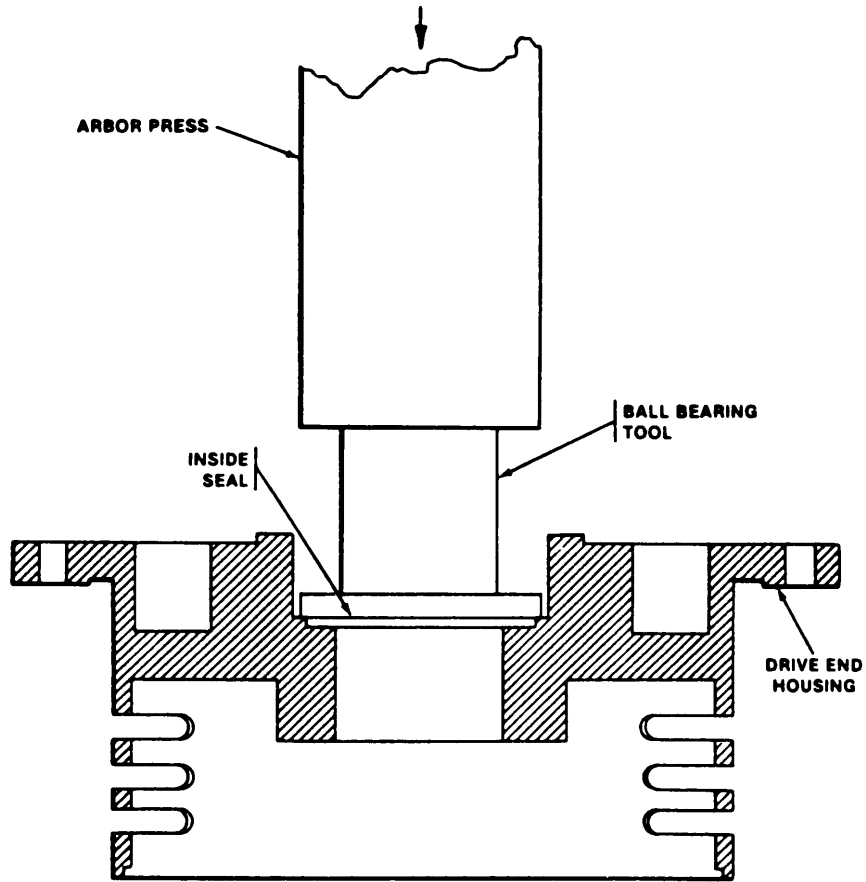

Figure 3-9. Assembly of Inside Seal in Drive End Housing Assembly.

NOTE

While applying grease, use finger to form the seal lips of inside seal as shown in figure 3-8.

(d) Apply thin film of grease (item 4, App B) to lips of inside seal.

(3) Install stator to drive end housing assembly (fig. 3-1).

NOTE

Aline locator pin in drive end housing assembly with matching hole in stator.

(a) Place stator (19) in anti-drive end housing (9) so that stator laminations fit flush in pilot bore of anti-drive end housing to protect stator windings.

(b) Place terminal block insulator (20) onto stator terminal studs so that hex cavities of insulator fit over hex portions of studs.

NOTE

Aline stator locator pin with matching hole in drive end housing.

(c) Place drive end housing assembly (21) over stator (19) so that three stator terminal studs pass through three holes in housing and stator locator pin meshes with matching hole in drive end housing assembly.

CAUTION

Insulator can crack if not properly aligned in depression in drive end housing assembly. Carefully align insulator in depression.

(d) place insulator (18) over stator terminal studs in drive end housing assembly (21) and secure with six spring washers (17), three flat washers (16), and nuts (15). Torque nuts to 16-18 pound-feet.

(e) Refer to figure 3-10 and connect three negative rectifier leads and three positive rectifier leads to stator terminal studs as follows:

1. Assemble negative rectifier leads (1, 2, and 3) to stator studs in that order, and secure with three nuts (15). Torque nuts to 12-14 pound-feet.

2. Assemble positive rectifier leads (4, 5, and 6) to stator terminal studs. Nuts will be installed in step (10)(e) 2 below.

(f) Remove stator (19) and drive end housing assembly (21) from anti-drive end housing (9) and place it on workbench with stator facing up.

(4) Install roller bearing to anti-drive end housing (fig. 3-1).

- (a) Place anti-drive end housing (9) in arbor press with exterior of housing facing up.

- (b) Place roller bearing (12) in position on bearing bore with lettered end of bearing facing up.

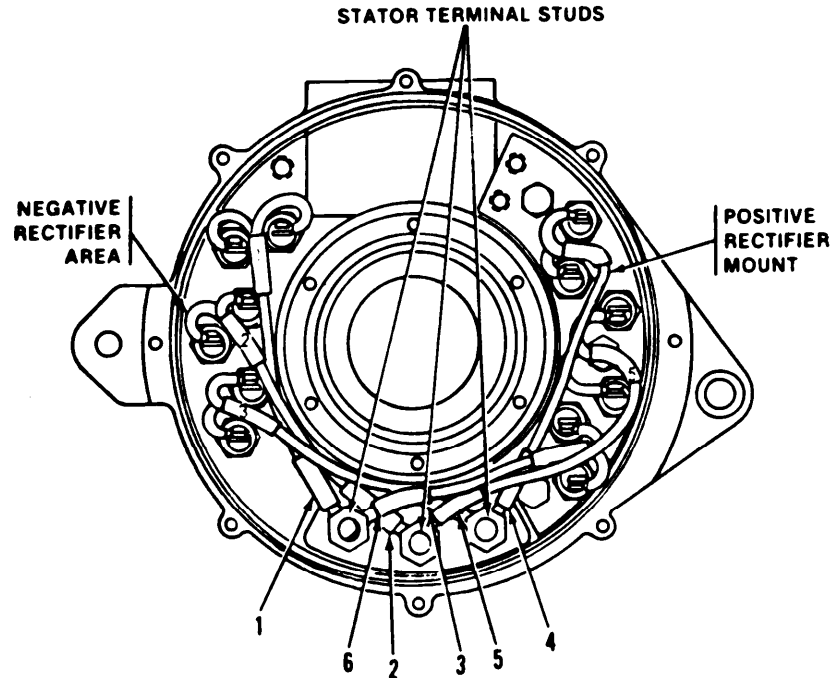

Legend:

- | | |
|---------------------------|---------------------------|
| 1 Negative rectifier lead | 4 Positive rectifier lead |
| 2 Negative rectifier lead | 5 Positive rectifier lead |
| 3 Negative rectifier lead | 6 Positive rectifier lead |

Figure 3-10. Rectifier Lead Connections.

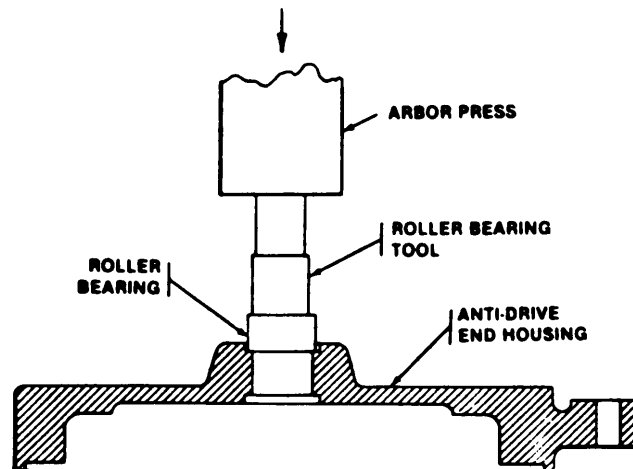

Figure 3-11. Roller Bearing Assembly.

(c) Place roller bearing tool (fig. F-1) on top of roller bearing according to figure 3-11. Press in bearing until it is flush in housing with outer seal shoulder.

(5) Install rotor and ball bearing in drive end housing assembly(fig.3-1).

(a) Place anti-drive end housing (9), with interior of housing facing up, on a vise with jaws opened approximately 4 inches.

(b) Place assembly spacer tool (fig. F-1) in anti-drive end housing (9) so that it is centered around bearing bore.

NOTE

Assembly spacer tool installed in step (b) above will be removed in step (g) below.

(c) Insert short end of shaft of rotor (14) in anti-drive end housing (9).

(d) Place stator (19) and drive end housing assembly (21) over rotor (14), and down into place on anti-drive end housing (9). Be sure that stator laminations fit flush in pilot bore of anti-drive end housing and that stator locator pin meshes with matching hole in anti-drive end housing.

(e) Place entire assembly in arbor press with drive end housing (21) facing up. Support assembly on hub area of anti-drive end housing (9) around shaft of rotor (14).

CAUTION

Ensure that ball bearing is pressed all the way down onto rotor shaft. Failure to do so may result in damage to the anti-drive end housing in later assembly steps. Front face of ball bearing must be at least 5/32 inch (3.97 mm) below front face of drive end housing.

(f) Place ball bearing (23) in position on bearing bore. Place ball bearing tool (fig. F-1) on top of bearing so that larger diameter end is in contact with bearing. Press bearing in until it bottoms out against bearing stop on shaft of rotor (14).

NOTE

Assembly spacer tool installed in step (b) above will be removed in step (g) below.

(g) Remove entire assembly from arbor press and remove anti-drive end housing (9) and assembly spacer tool (fig. F-1) used to position rotor (14) during rotor assembly. Install anti-drive end housing on shaft of rotor, making sure that stator laminations fit flush in pilot bore of anti-drive end housing and stator locating pin meshes with matching hole in anti-drive end housing.

(h) Place entire assembly in arbor press with drive end housing assembly (21) facing up, supporting assembly on hub area of anti-drive end housing (9) around shaft of rotor (14).

(i) Place ball bearing tool (fig. F-1) on top of bearing (23) so that larger diameter end is in contact with bearing. Press bearing in until it bottoms out in bearing bore of drive end housing assembly (21).

(j) Fill cavity around area of shaft of rotor (14) and coat surface of bearing (23) with grease (item 4, App B).

(k) Install spacer (25) on shaft of rotor (14), all the way down against bearing. (23).

(6) Install outer seal in drive end housing assembly (fig. 3-1).

(a) Apply a thin film of grease (item 4, App B) to lips of outer seal (24). Place seal in position on seal bore of drive end housing assembly (21) with seal lips flaring up. See figure 3-8 for proper seal lip position.

(b) Using a plastic mallet, gently tap outer seal (24) in seal bore until it is flush with outside surface of drive end housing assembly (21).

(c) Remove entire assembly from arbor press.

(7) Install inside seal and outer seal on anti-drive end housing (fig. 3-1).

(a) Remove anti-drive end housing (9) from generator assembly.

(b) Place anti-drive end housing (9) in arbor press with external side of housing resting on base of press.

NOTE

Inner seal in anti-drive end housing is to be assembled so that seal lips flare inward toward rotor.

(c) Apply thin film of grease (item 4, App B) to lips of inside seal (10). Place seal in position on the seal bore of anti-drive end housing (9) with seal lips flaring inward, toward rotor (14). See figure 3-8 for proper seal lip position.

(d) Press inside seal (10) into seal bore until it is flush with face of anti-drive end housing (9).

(e) Turn anti-drive end housing (9) over in arbor press.

NOTE

Outer seal in anti-drive end housing is to be assembled so that seal lips flare outward, away from rotor.

(f) Apply thin film of grease (item 4, App B) to lips of outer seal (11). Place outer seal in position on the seal bore of anti-drive end housing (9) with seal lips flaring outward, away from rotor (14). See figure 3-8 for proper seal lip position.

(g) Press outer seal (11) into seal bore until it is flush with face of anti-drive end housing (9).

(8) Install slideable bushing in anti-drive end housing ear (fig. 3-1).

(a) Place anti-drive end housing (9) in arbor press so that inner side of anti-drive end housing (side nearest rotor (14)) faces up. Housing ear must be supported.

(b) Press slideable bushing (13) into ear on anti-drive end housing (9) until flush.

(9) Install anti-drive end housing on drive end housing assembly (fig. 3-1).

(a) Slide anti-drive end housing (9) on shaft of rotor (14).

(b) Push anti-drive end housing (9) tightly against stator (19) making sure that stator locator pin meshes with matching hole in anti-drive end housing.

(c) Insert four screws (7) with lock washers (8) through holes in anti-drive end housing (9) and thread them into holes in drive end housing assembly (21). Tighten screws securely.

(10) Install brush holder, brushes, and printed circuit panel assembly in drive end housing assembly (fig. 3-3). Use figure 3-12 as a guide when making lead connections.

(a) Assemble brush assembly unit (12) as follows:

1. Install two brush assemblies (9) into two holes of brush holder (10), with tabs at end of brush springs placed in shallow cavities of brush holder.

2. Place brush cover (8) in position on top of brush holder (10), routing brush leads through holes in brush cover.

(b) Assemble circuit panel assembly unit (11) as follows:

1. Assemble four screws (1), lock washers (2), washers (3), and insulations washers (4) on top of printed circuit panel assembly (5).

2. Push four screws (1) through printed circuit panel assembly (5). Place a spacer (7) on each of the four screws.

(c) Assemble printed circuit panel assembly unit (11) to brush assembly unit (12).

1. Route black leads from two brush assemblies (9) through hole in printed circuit panel assembly (5).

2. Route four screws (1) from printed circuit panel assembly unit (11) through four holes in brush assembly unit (12).

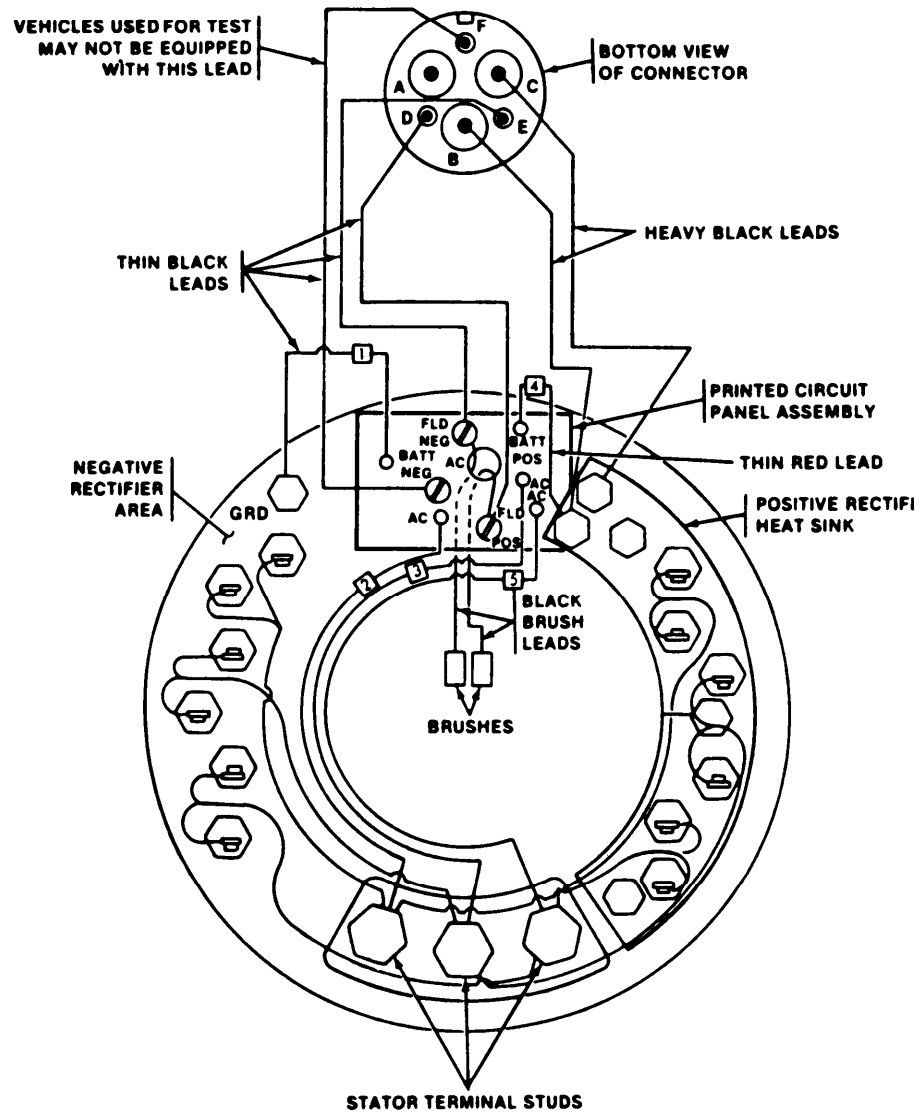

Figure 3-12. Drive End Housing Assembly Interconnection Diagram.

NOTE

Have helper assist in steps (d) and (e) below.

(d) Install combined circuit panel assembly unit (11) and brush assembly unit (12) in drive end housing assembly (6). Tighten four screws (1).

(e) Install leads as follows, using figure 3-10 as a guide for making lead connections.

1. Secure short black lead from printed circuit panel assembly (5) to housing ground hole in drive end housing assembly (6) using screw (11, fig. 3-2). Tighten screw securely.

2. Secure each of the three long black leads from printed circuit panel assembly (5) to each of the three stator terminal studs using three nuts (10, fig. 3-2). Route leads in cavity of drive end housing assembly (6) along with negative rectifier leads. Torque nuts to 12-14 pound-feet.

(11) Install mounting plate and connector assembly to drive end housing assembly (fig. 3-2). Use figure 3-2 and figure 3-12 to make lead connections.

(a) Route two heavy black connector leads through brush holder cavity in drive end housing assembly (6) to positive rectifier area of drive end housing assembly.

(b) Secure three thin black connector leads and two black brush leads to printed circuit panel assembly (7) using three screws (8) and lock washers (9). Tighten screws securely.

(c) Secure connector assembly (4) and mounting plate (5) on drive end housing assembly (6) using four screws (2) and lock washers (3). Tighten screws securely.

CAUTION

Care must be taken to ensure terminals do not touch any portion of drive end housing assembly. Failure to do so will result in damage to equipment.

(d) Secure two heavy black connector leads and one thin red lead from printed circuit panel assembly (7) to Positive rectifier heat sink using two brass bolts (1). Tighten bolts securely.

(12) Install cover plate on drive end housing assembly (fig. 3-1).

NOTE

When assembling cover plate, use black paint outline and scribe marks on drive end housing assembly as a guide to ensure proper orientation of cover on housing.

(a) Install cover plate (6) on front face of drive end housing assembly (21) using six screws (4) and eight screws (5).

(b) Tighten screws securely.

(13) Install fan (fig. 3-1).

(a) Install key (3) in key slot of shaft of rotor (14).

(b) Clamp pulley end of shaft of rotor (14), with key (3) inserted in key-slot, in vise with soft-jaw caps to keep generator shaft from turning.

CAUTION

When tightening nut, do not attempt to keep generator shaft from turning by inserting a screwdriver or any other tool in between fan blades. To do so could result in damage to fan.

(c) Slide fan (2) on shaft with fan fins facing generator, and secure with self-locking nut (1). Torque nut to 30-35 pound-feet.

(d) Remove generator from vise.

f. Generator Performance Test. See **Appendix E.**

Section II. PN N1205 AND N1206

3-4. GENERAL INSTRUCTIONS

- a. The procedures discussed in this section cover complete disassembly of the generator.
- b. In cases where the generator does not require complete disassembly, disassemble only to the point required to inspect, clean, and replace the damaged component.

3-5. GENERATOR REPAIR INSTRUCTIONS

- a. Generator Cleaning Procedures.

(1.) Clean exterior surfaces of generator as follows:

- (a.) Clean exterior surface of generator with cloth (item 5, App B) dipped in dry cleaning solvent (item 2, App B).
- (b.) Dry thoroughly with compressed air or dry cloth (item 5, App B).

NOTE

Compressed air must not exceed 10 psig.

WARNING

Eye injury can occur if eye shields are not worn when using compressed air to blow dirt or other particles off rotor slip rings.

b. Generator Disassembly Procedure.

CAUTION

The generator weighs approximately 80 lb. To prevent personal injury or damage to the generator, get a helper when mounting the generator in the vise.

NOTE

Perform steps 1 through 4 only as required.

NOTE

Place soft-jaw caps on vise when holding generator pulley.

- (1.) Remove pulley nut (1) and hardened washer (2). Do not loosen the fan nut at this time.
- (2.) Using a puller (item 7, App D), remove the pulley (3) from the core and shaft (4).
- (3.) Remove woodruff key (5) and bushing (6) from shaft.

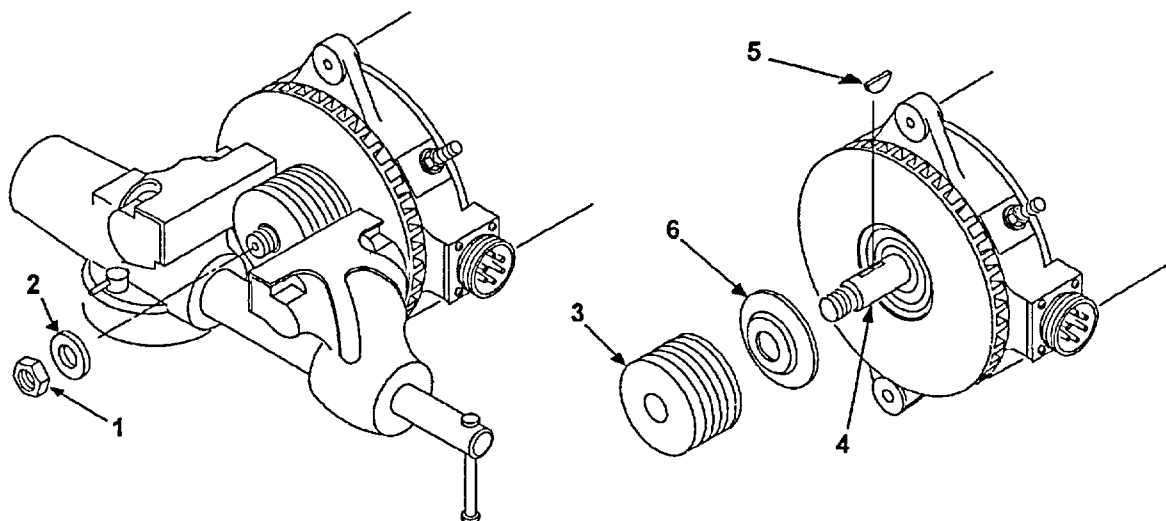

(4.) Remove nut (7), hardened washer (8), and fan assembly (9) from shaft (4).

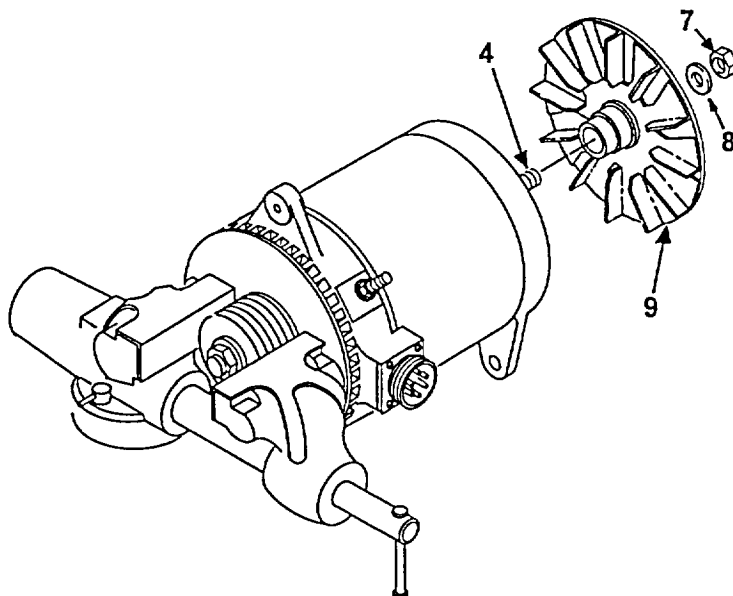

(5.) Remove nine flanged locknuts (10) from rear housing (11). Discard locknuts.

(6.) Using a puller (item 7, App. D), remove rear housing(11) from stator shell (12).

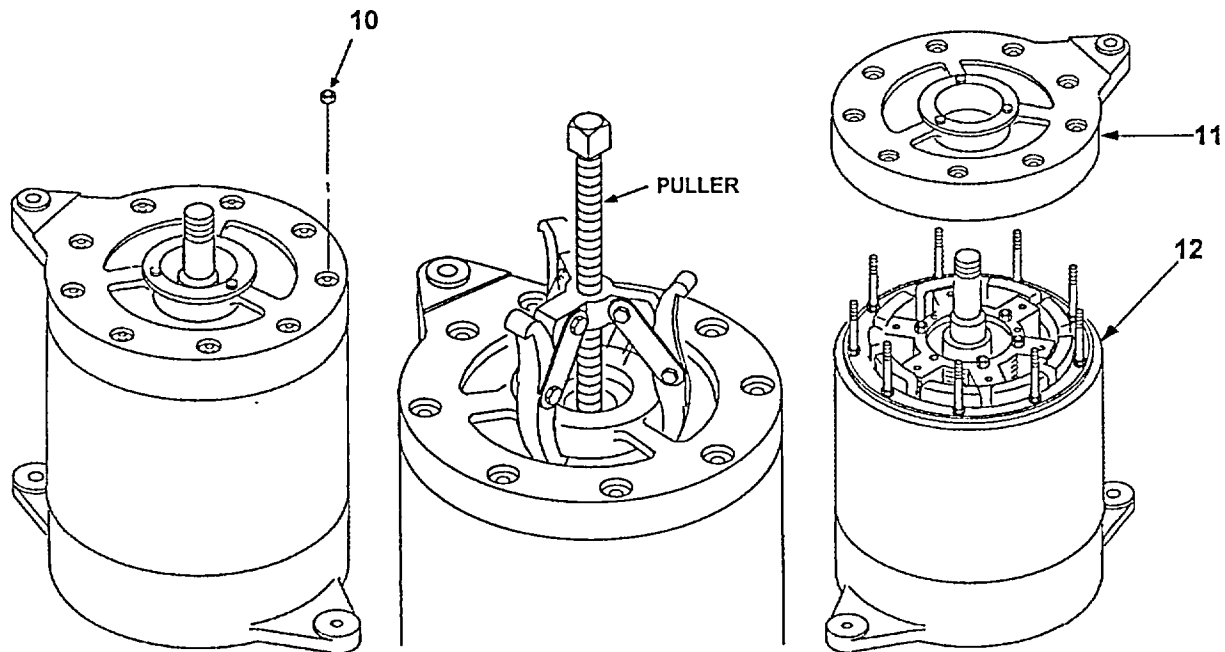

(7.) Using a puller (item 7, App D.), remove rear bearing (15) from core and shaft.

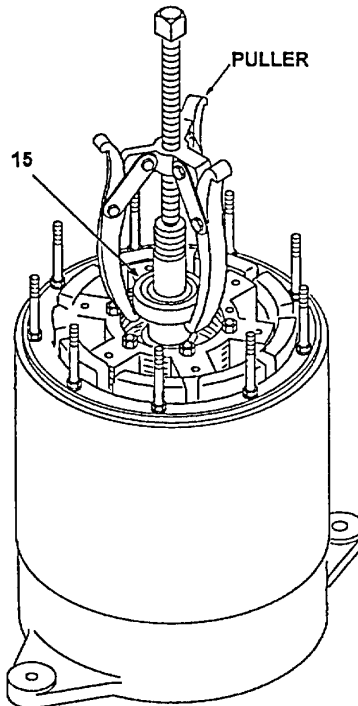

(8.) Remove six flange nuts (13) from core and shaft studs.

(9.) Use three 10-32 UNF X 2 inch long machine screw as jackscrews. Install three screws in threaded holes of rotor end plate. Pull rotor from core by gradually working screws against core in sequence.

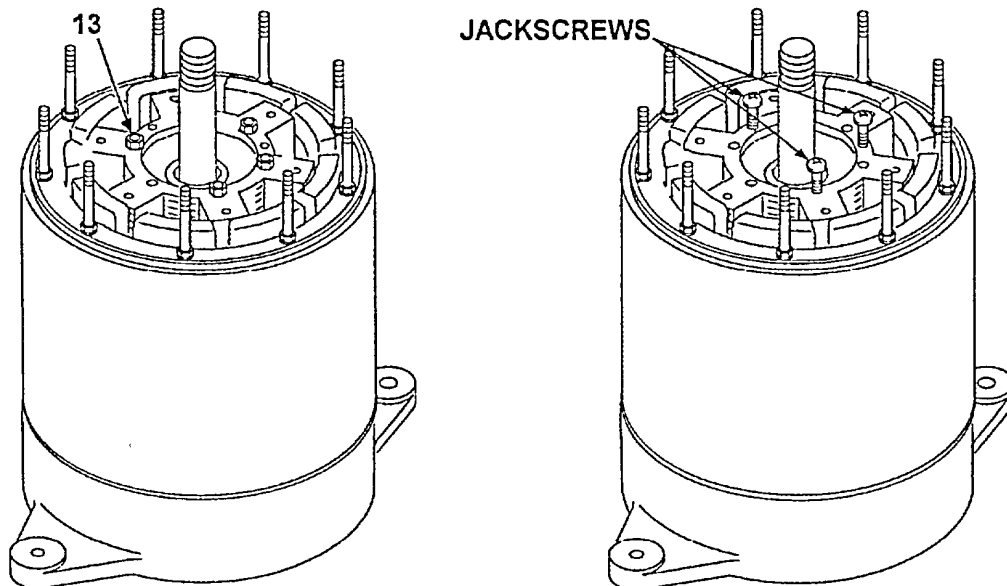

NOTE

Scribe cover plate and front housing before removing cover plate

- (10.) Remove six screws (16) and cover (17) from front housing (18).

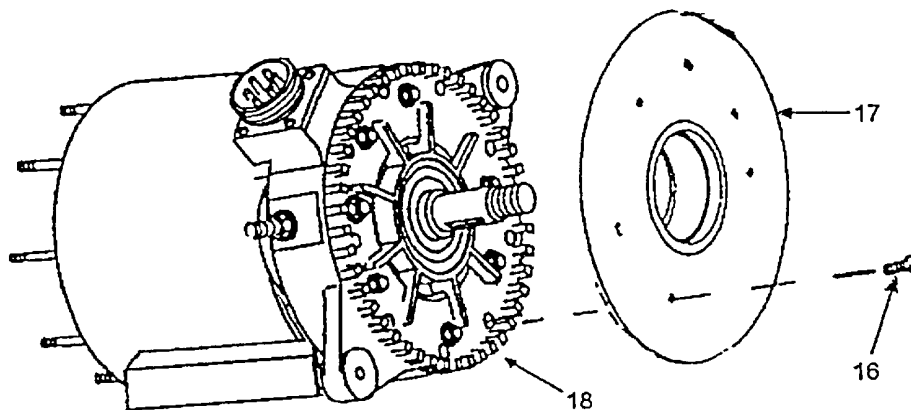

NOTE

There are two connector assembly configurations, both procedures for removal and repair are the same.

- (11.) Remove connector assembly from front of housing. Tag all leads. See page 3-6 steps 3 and 4 for procedure to remove connector assembly.

NOTE

Mark front housing and stator shell to insure proper alignment when generator is reassembled

- (12.) Remove nine flanged locknuts (10), front housing (18), with core and rotor attached from studs on stator housing (12). Discard locknuts.

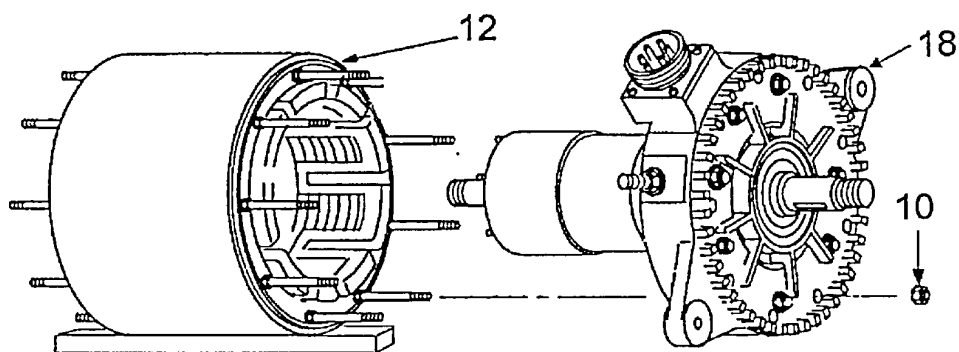

NOTE

Light taps with a soft-faced mallet will help in the separation of the parts.

(13.) Remove retaining ring (20) from core and shaft (4).

(14.) Using an arbor press (item 4, App D), remove the core and shaft (4) from the front housing (18) by pressing shaft down through the front bearing (21).

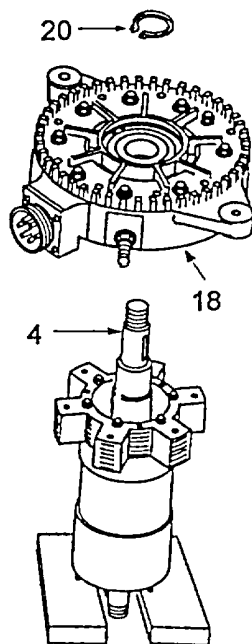

(15.) Remove two retaining rings (22 and 23) from front housing (16).

(16.) Support front housing on blocks and with an arbor press (item 4, App D), remove front bearing (21).

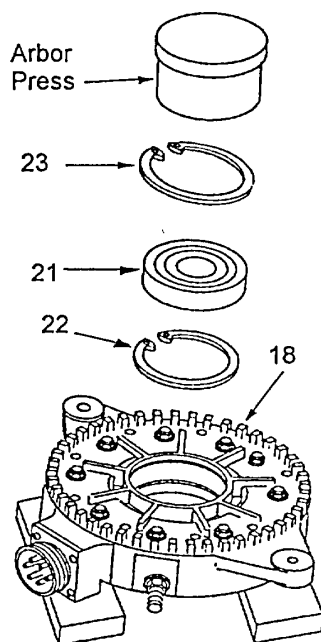

- (17.) Remove six flange nuts (24) from core and shaft (4) studs.
- (18.) Use three 10-32 UNF x 2 inch long machine screw as jacks. Install screws in threaded holes of front rotor (19) end plate. Pull front rotor from core by gradually working screws against core in sequence.

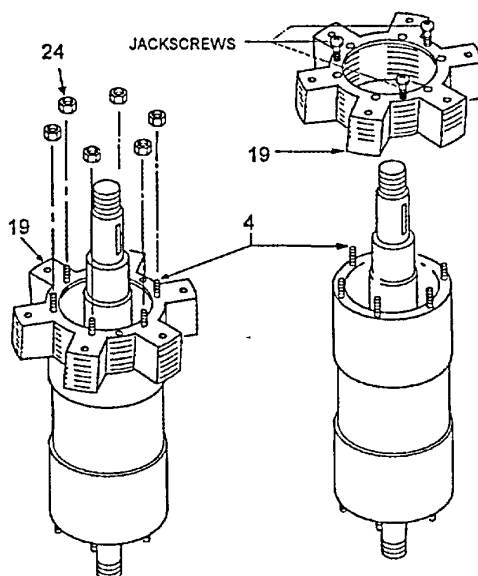

c. N1205/N1206 Generator Assembly Procedures.

- (1.) Clean bearing's inside diameter surface of front housing (18).

NOTE

Retaining ring (22) has two flat surfaces.

- (2.) Install retaining ring (22) in square groove towards front of the front housing.
- (3.) Coat outer face of front bearing (21) with a thin coat of sealing compound (item 7, App D)
- (4.) Using a arbor press (item 4, App D), press front bearing (21) into front housing (18) until bearing seats against retaining ring (22).
- (5.) Install retaining ring (23) in front housing (18) groove.

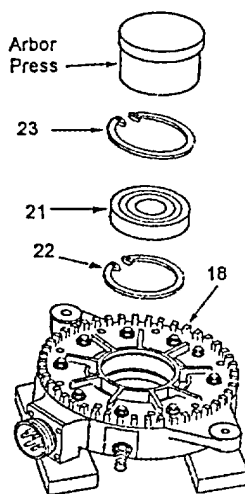

(6.) Install rotor assembly (19) on shaft and core assembly (4). Place rotor over end of shaft with woodruff key slot (front of shaft).

NOTE
Center studs in core with slots in rotor plate.

(7.) Apply primer (item 6, App B.) and sealing compound (item 7, App. B) to threads of core and shaft studs. Secure rotor (19) to core and shaft (4) with six flange nuts (24). Torque nuts to 45 in-lb.

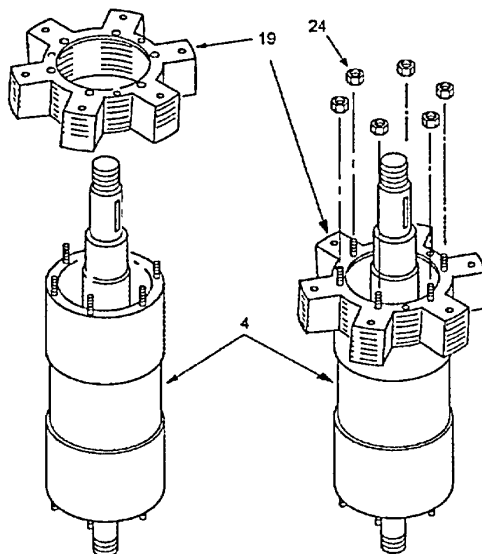

(8.) Support rotor (19) and shaft and core assembly (4) on blocks with the bearing surface down.

(9.) Place front bearing (21) in front housing (18) on core and shaft (4). Using an arbor press (item 4, App D) press bearing onto shaft until inner race seats on shaft shoulder.

(10.) Install retaining ring (20) on core and shaft assembly (4).

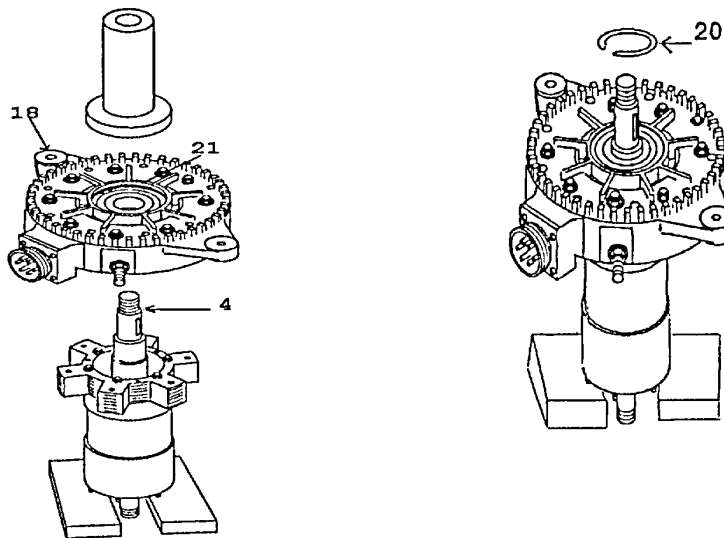

CAUTION

Care must be used when placing stator shell (12) on blocks to prevent damage to stator windings and shell studs.

- (11.) Support stator shell (12) on blocks with the six phase leads (black wires) and the two field leads pointing up.

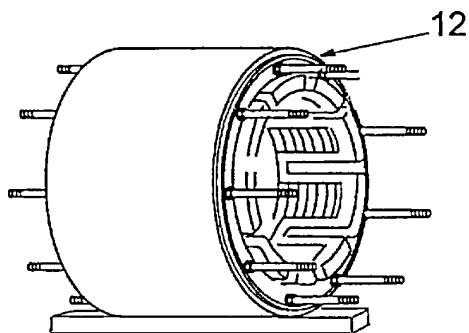

NOTE

Normal mounting position is between the 1st and 2nd drain holes starting from the left. (Closer to middle hole.) As the stator shell studs come through the holes in the front housing, allow the phase leads (black wires) and the field leads to come through the large openings in the front housing.

- (12.) Align front housing (18) with the position marks on the generator core into the stator shell.
 (13.) Install nine new flanged locknuts on stator shell studs. Tighten locknuts to 18 in-lb torque.

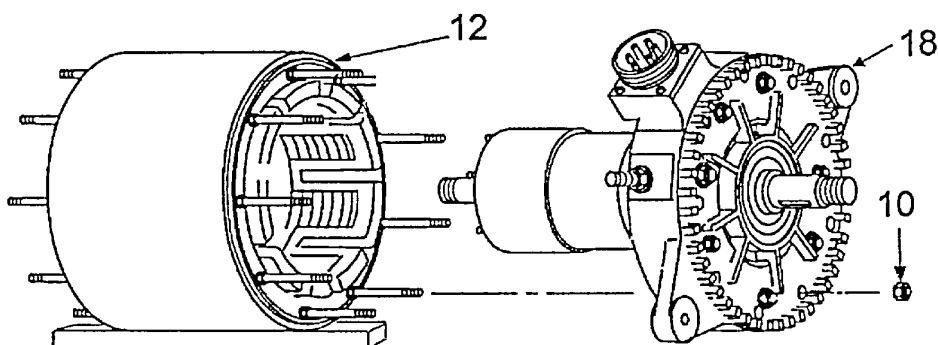

- (14.) Install six phase leads, two field leads, and six nuts on front housing.

NOTE

There are two connector assembly configurations, both procedures for installation are the same.

- (15.) Install connector assembly from front of housing. See page 3-26 step 11 for procedures to install connector assembly.

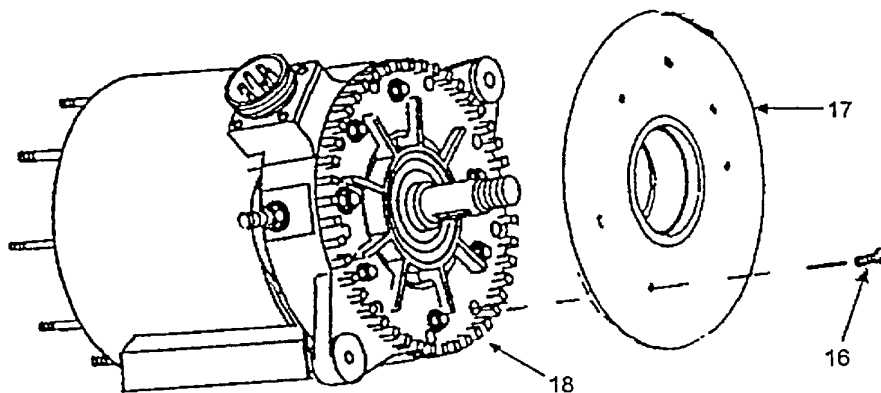

(16.) Install cover (17 and six screws (16) on front housing (18).

(17.) Place rotor (14) on core and shaft assembly (4).

(18.) Apply primer (item 6, App B) and sealing compound (item 7, App B) to threads of core and shaft studs. Secure rotor (14) to core and shaft (4) with six flange nuts (13). Tighten nuts to 45 in-lb.

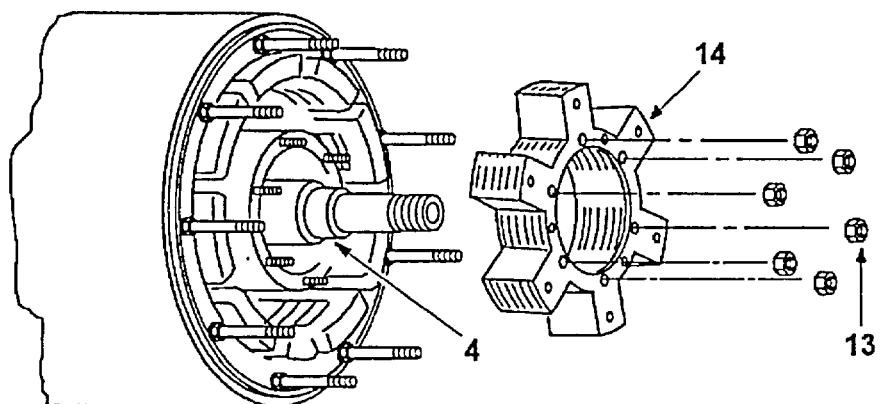

(19.) Support generator assembly on front housing (18).

NOTE

End housing (11) mounting foot should line up with front housing (12) mounting foot.

(20.) Place end housing (11) on stator shell (12) and using arbor press (item 7, App D), press end housing onto stator shell until seated against shell (minimal force is required).

(21.) Install nine new flanged locknuts (10) on stator shell studs. Tighten locknuts to 18 in-lb torque.

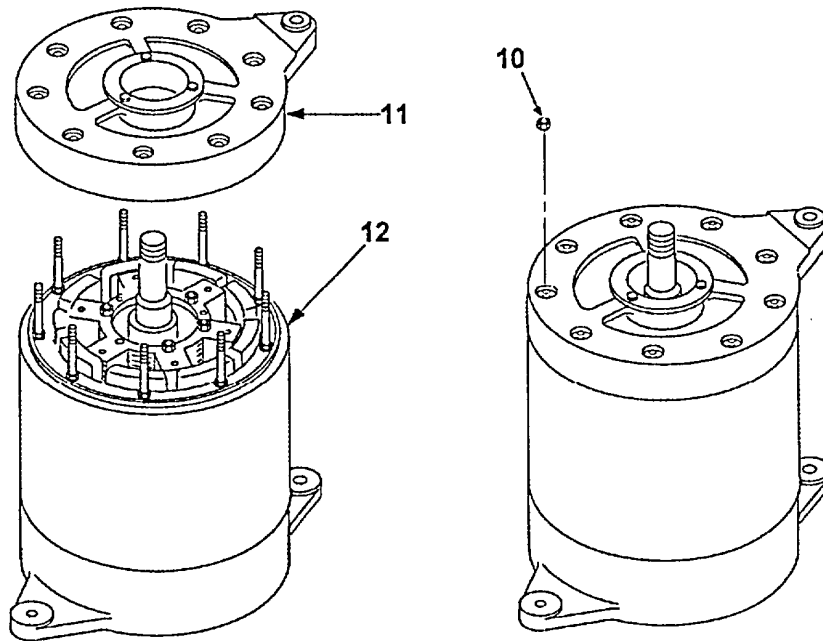

CAUTION

Care must be taken when pressing the bearing into the housing. Use caution as the bearing outer race begins to enter the end housing bore. Misalignment can damage the end housing.

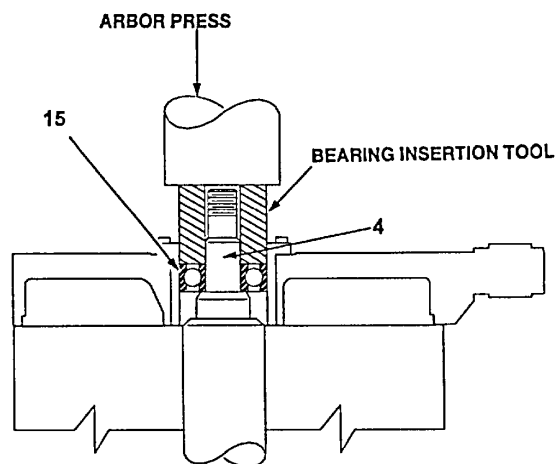

(22.) Using an arbor press (item 4, App D), press bearing (15) onto core and shaft assembly (4).

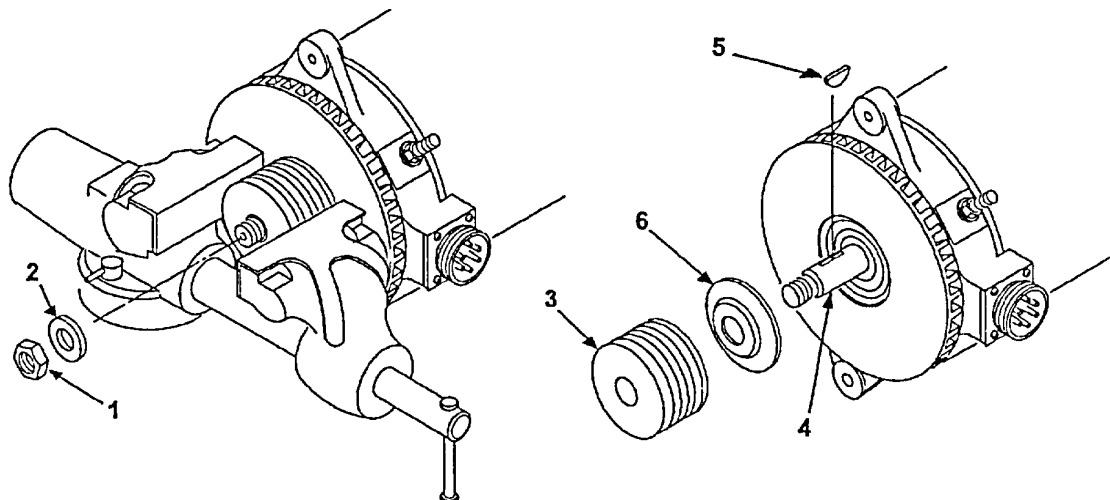

- (23.) Install pulley bushing (6) on generator shaft.
- (24.) Press woodruff key (5) into shaft.
- (25.) Align pulley (3) with woodruff key (5) and install on generator shaft.
- (26.) Install hardened washer (2) and pulley nut (1) on shaft.

NOTE

Support the generator and clamp the pulley in a vise with protective jaw caps. Tighten the nut to 120 ft-lb torque.

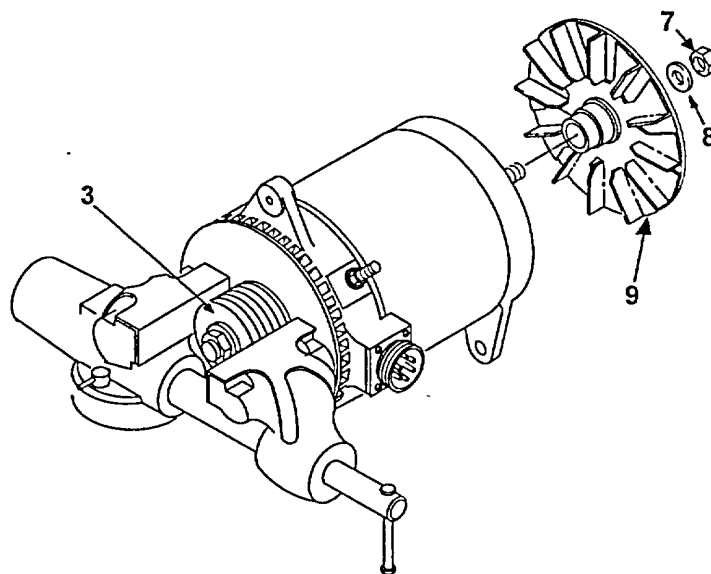

- (27.) Place fan assembly (9) on shaft from end housing (11).
- (28.) With pulley (3) in vise, install washer (8) and nut (7) on generator shaft. Tighten nut to 50 ft-lb torque. Remove generator from vise.

d. Generator Performance Test. See Appendix E.

APPENDIX A

REFERENCES

- TM 9-4910-485-12Operator and Organizational Maintenance Manual (Including Repair Parts and Special Tool List): Test Stand, Automotive Generator, Alternator, and Starter, Floor Mounted, 10 to 50 V, 500 AMP, AC, Testing Ranges with 8000 to 12,000 RPM, 22 1/2 HP, 220/440 V, 100 to 400V, 60 Cycle, 3 Phase Dual Head Vari-Driven Assembly (Sun Electric Model AGT-9 and AGT-9A).

- TM 9-4910-663-12Operator's and Organizational Maintenance Manual for Test Stand, Automotive Generator, Alternator Starter and Associated Equipment, Model GASR-500.

- TM 9-2350-247-10Operator's Manual for: M548A1 Tracked, 6-Ton Cargo Carrier; M548A3 Tracked, 6-Ton Cargo Carrier; M1015A1 Tracked, 6-Ton Electronic Warfare Systems Carrier.

- TM 9-2350-261-10Operator's Manual for: M113A2 Armored, Full Tracked Personnel Carrier; M577A2 Light Tracked Command Post Carrier; M106A2 Self-Propelled, 107MM Mortar Carrier; M125A2 Self-Propelled, 81MM Mortar Carrier; M1064 Self-Propelled, 120MM Mortar Carrier; M1059 Full Tracked Smoke Generator Carrier; M1068 Standardized Integrated Command Post System.

- TM 9-2350-277-10Operator's Manual for: M113A3 Armored, Full Tracked Personnel Carrier; M577A3 Light Tracked Command Post Carrier; M901A3 Armored, Full Tracked, Anti-TOW Carrier; M981A3 Armored, Full Tracked Fire Support Personnel Carrier; M1059A3 Full Tracked Smoke Generator Carrier; M1064A3 Self-Propelled, 120MM Mortar Carrier; M1068A3 Standardized Integrated Command Post System; 58 Mechanized Smoke Obscurant Chassis.

APPENDIX B

EXPENDABLE SUPPLIES AND MATERIALS LIST

ITEM NUMBER	LEVEL	NATIONAL STOCK NUMBER	DESCRIPTION FSCM & PART NUMBER	U/M
1	F	5350-00-221-0872	Cloth, Abrasive, Crocus (81348) P-C-458	sh.
2	F	6850-01-277-0595	Dry Cleaning Solvent (59557) 134-HI-SOLV	gl.
3	F		Enamel, Epoxy Insulating, Red (11927) 32230CM	gl.
4	F	9150-00-944-8953	Grease, Aircraft General Purpose, Wide Temperature Range (81349) MIL-G-81322	lb.
5	F	7920-00-205-1711	Rag, Wiping, Cotton and Cotton Synthetic (81349) DDD-R-30, Grade B	lb.
6	F	8030-00-181-8372	Sealing Compound, Primer (05972) 747-56	cn.
7	F	8030-00-081-2329	Sealing Compound (05972) 88-21	tu.

APPENDIX C

DIRECT SUPPORT MAINTENANCE
REPAIR PARTS AND SPECIAL TOOLS LIST

Section I. Introduction

C-1. Scope. This appendix lists spares and repair parts; special tools; special test, measurement, and diagnostic equipment (TMDE); and other special support equipment required for performance of direct support maintenance of the 200 AMP engine generator. It authorizes the requisitioning and issue of spares and repair parts as indicated by the source and maintenance codes.

C-2. General. This Repair Parts and Special Tools List is divided into the following sections:

a. Section II. Repair Parts Lists. A list of spares and repair parts authorized for use in the performance of maintenance. The list also includes parts which must be removed for replacement of the authorized parts. Parts lists are composed of functional groups in alpha sequence, with the parts in each group listed in figure and item number sequence. Bulk materials are listed in NSN sequence.

b. Section III. Special Tools List. See Chapter 1, Section II, Special Tools and Equipment.

c. Section IV. National Stock Number and Part Number Index. A list, in National item identification number (NIIN) sequence, of all National stock numbers (NSN) appearing in the listings, followed by a list, in alphanumeric sequence, of all part numbers appearing in the listings. National stock numbers and part numbers are cross-referenced to each illustration figure and item number appearance.

C-3. Explanation of Columns.

a. Illustration. This column is divided as follows:

(1) Figure number. Indicates the figure number of the illustration in which the item is shown.

(2) Item number. The number used to identify each item called out in the illustration.

b. Source, Maintenance, and Recoverability (SMR) Codes.

(1) Source code. Source codes indicate the manner of acquiring support items for maintenance, repair, or overhaul of end items. Source codes are entered in the first and second positions of the Uniform SMR Code format as follows:

Code

Definition

- | | |
|----|--|
| PA | - Item procured and stocked for anticipated or known usage. |
| PB | - Item procured and stocked for insurance purpose because essentiality dictates that a minimum quantity be available in the supply system. |
| PC | - Item procured and stocked and which otherwise would be coded PA except that it is deteriorative in nature. |
| PD | - Support item, excluding support equipment, procured for initial issue or outfitting and stocked only for subsequent or additional initial issues or outfittings. Not subject to automatic replenishment. |
| PE | - Support equipment procured and stocked for initial issue or outfitting to specified maintenance repair activities. |
| PF | - Support equipment which will not be stocked but which will be centrally procured on demand. |

- PG -Item procured and stocked to provide for sustained support for the life of the equipment. It is applied to an item peculiar to the equipment which, because of probable discontinuance or shutdown of production facilities, would prove uneconomical to reproduce at a later time.
- KD -An item of depot overhaul/repair kit and not purchased separately. Depot kit defined as a kit that provides items required at the time of overhaul or repair.
- KF -An item of a maintenance kit and not purchased separately. Maintenance kit defined as a kit that provides an item that can be replaced at organizational or intermediate levels of maintenance.
- KB -Item included in both a depot overhaul/repair kit and a maintenance kit.
- MO -Item to be manufactured or fabricated at organizational level.
- MF -Item to be manufactured or fabricated at the direct support maintenance level.
- MH -Item to be manufactured or fabricated at the general support maintenance level.
- MD -Item to be manufactured or fabricated at the depot maintenance level.
- AO -Item to be assembled at organizational level.
- AF -Item to be assembled at direct support maintenance level.
- AH -Item to be assembled at the general support maintenance level.
- AD -Item to be assembled at depot maintenance level.
- XA -Item is not procured or stocked because the requirements for the item will result in the replacement of the next higher assembly.
- XB -Item is not procured or stocked. If not available through salvage, requisition.
- XC -Installation drawing, diagram, instruction sheet, field service drawing, that is identified by manufacturer's part number.
- XD - A support item that is not stocked. When required, item will be procured through normal supply channels.

NOTE

Cannibalization or salvage may be used as a source of supply for any items coded above except those coded XA and aircraft support items as restricted by AR 700-42.

(2) Maintenance code. Maintenance codes are assigned to indicate the levels of maintenance authorized to USE and REPAIR support items. The maintenance codes are entered in the third and fourth positions of the Uniform SMR code format as follows:

(a) The maintenance code entered in the third position will indicate the lowest maintenance level authorized to remove, replace, and use the support item. The maintenance code entered in the third position will indicate one of the following levels of maintenance:

<u>Code</u>	<u>Application/Explanation</u>
C	- Crew or operator maintenance performed within organizational maintenance.
O	- Support item is removed, replaced, used at the organizational level.
F	- Support item is removed, replaced, used at the direct support level.
H	- Support item is removed, replaced, used at the general support level.
D	- Support items that are removed, replaced, used at depot, mobile depot, or specialized repair activity only.

(b) The maintenance code entered in the fourth position indicates whether the item is to be repaired and identifies the lowest maintenance level with the capability to perform complete repair (i.e., all authorized maintenance functions). This position will contain one of the following maintenance codes:

<u>Code</u>	<u>Application/Explanation</u>
O	- The lowest maintenance level capable of complete repair of the support item is the organizational level.
F	- The lowest maintenance level capable of complete repair of the support item is the direct support level.
H	- The lowest maintenance level capable of complete repair of the support item is the general support level.
D	- The lowest maintenance level capable of complete repair of the support item is the depot level.
L	- Repair restricted to designated specialized repair activity.
Z	- Nonreparable. No repair is authorized.
B	- No repair is authorized. The item may be reconditioned by adjusting, lubricating, etc., at the user level. No parts or special tools are procured for the maintenance of this item.

(3) Recoverability code. Recoverability codes are assigned to support items to indicate the disposition action on unserviceable items. The recoverability code is entered in the fifth position of the uniform SMR code format as follows:

<u>Codes</u>	<u>Definition</u>
Z	- Nonreparable item. When unserviceable, condemn and dispose at the level indicated in position 3.
O	- Reparable item. When uneconomically repairable, condemn and dispose at organizational level.
F	- Reparable item. When uneconomically repairable, condemn and dispose at the direct support level.
H	- Reparable item. When uneconomically repairable, condemn and dispose at the general support level.

- D - Reparable item. When beyond lower level repair capability, return to depot. Condemnation and disposal not authorized below depot level.
- L - Reparable item. Repair, condemnation, and disposal not authorized below depot/specialized repair activity level.
- A - Item requires special handling or condemnation procedures because of specific reasons (i.e., precious metal content, high dollar value, critical material, or hazardous material). Refer to appropriate manuals/directives for specific instructions.

c. Federal Supply Code for Manufacturer (FSCM). The FSCM is a 5-digit numeric code listed in SB 708-42 which is used to identify the manufacturer, distributor, or Government agency, etc.

d. Part Number. Indicates the primary number used by the manufacturer (individual, company, firm, corporation, or Government activity), to identify an item or range of items. This part number controls the design and characteristics of the item or range of items by means of its engineering drawings, specifications standards, and inspection requirements.

NOTE

When a stock numbered item is requisitioned, the item received may have a different part number than the part being replaced.

e. Description. Indicates the Federal item name and, if required, a minimum description to identify the item. Items that are included in kits and sets are listed below the name of the kit or set with the quantity of each item in the kit or set indicated in the quantity incorporated in unit column. When the part to be used differs between serial numbers of the same model, the effective serial numbers are shown as the last line of the description.

f. Quantity Incorporated in Unit. Indicates the quantity of the item used in the breakout shown on the illustration figure, which is prepared for a functional group, subfunctional group, or an assembly. A "V" appearing in this column in lieu of a quantity indicates that no specific quantity is applicable (e.g., shims, spacers, etc.).

C-4. Special Information. NPN items (items which have no P/N) will be drawn as "hard-line" art on the figure illustration, and identified by an arrow and the same callout number as the NHA to which the item reports and enclosed within parenthesis. No tabulated listing will appear for NPN coded items.

C-5. How to Locate Repair Parts.

a. When National stock number or part number is unknown:

(1) First. Using the table of contents, determine the functional group within which the item belongs. This is necessary since illustrations are prepared for functional groups and listings are divided into the same groups.

(2) Second. Find the illustration covering the functional group to which the item belongs.

(3) Third. Identify the item on the illustration and note the illustration figure and item number of the item.

(4) Fourth. Using the Repair Parts Listing, find the figure and item number noted on the illustration.

b. When National stock number or part number is known:

(1) First. Using the Index of National Stock Numbers and Part Numbers, find the pertinent National stock number or part number. This index is in ascending NIIN sequence followed by a list of part numbers in alphanumeric sequence, cross-referenced to the illustration figure number and item number.

(2) Second. After finding the figure and item number, locate the figure and item number in the repair parts list.

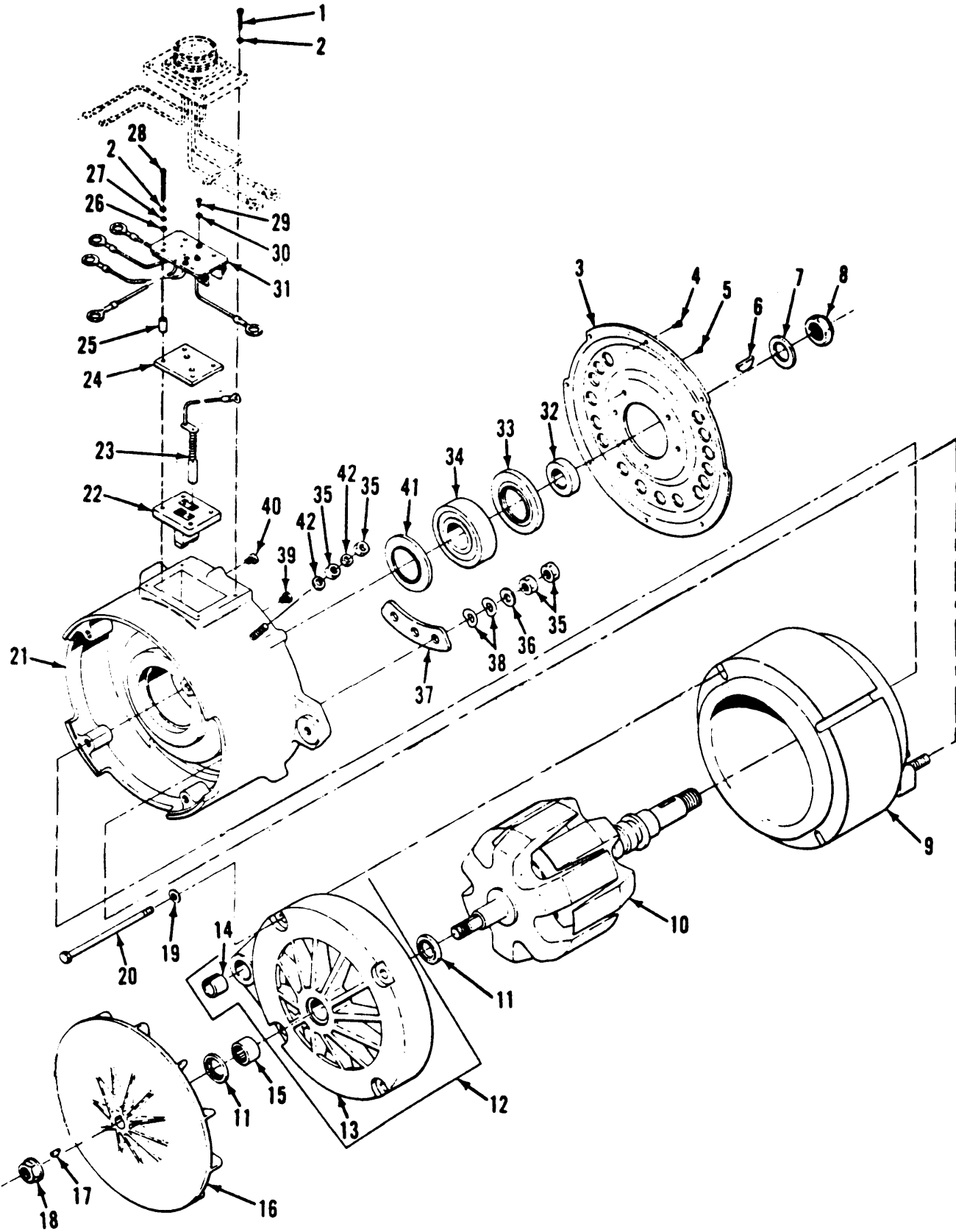

Figure 1. 200 AMP Generator.

SECTION II. REPAIR PARTS LIST.

ILLUS						QTY
FIG	ITEM			PART		INC
NO.	NO.	SMR	FSCM	NUMBER	DESCRIPTION	IN
						UNIT
GROUP 06 ELECTRICAL SYSTEM						
GROUP 0601 GENERATOR						
FIG. 1 200 AMP GENERATOR						
12320970						
1	1	PAFZZ	96906	MS35265-47	SCREW, MACHINE	4
1	2	PAFZZ	96906	MS35338-42	WASHER, LOCK	8
1	3	PAFZZ	19207	12321010	COVER, ELECTRICAL	1
1	4	PAFZZ	19207	12325869	BOLT, MACHINE	8
1	5	PAFZZ	96906	MS51960-65	SCREW, MACHINE	6
1	6	PAOZZ	96906	MS35756-16	KEY, WOODRUFF	1
1	7	PAOZZ	88044	AN960-1216	WASHER, FLAT	1
1	8	PAOZZ	96906	MS21245L12	NUT, SELF-LOCKING	1
1	9	PAFZZ	19207	12320981	STATOR ASSEMBLY	1
1	10	PAFZZ	19207	12320980	ROTOR ASSEMBLY	1
1	11*	KFFZZ	19207	12320986	SEAL, ROTOR SHAFT	2
1	12	PAFFF	19207	12321012	HOUSING, END	1
1	13	XAFZZ	19207	12320979	HOUSING	1
1	14	PAFZZ	19207	12321011	BUSHING, SLEEVE	1
1	15*	KFFZZ	19207	12320984	BEARING, ROLLER, CY	1
1	16	PAFZZ	19207	12320983	IMPELLER, GENERATO	1
1	17	PAFZZ	96906	MS35756-10	KEY, WOODRUFF	1
1	18*	KFFZZ	96906	MS51988-12	NUT, SELF-LOCKING,	1
1	19	PAFZZ	96906	MS35338-45	WASHER, LOCK	4
1	20	PAFZZ	96906	MS90725-50	BOLT, MACHINE	4
1	21	PAFZZ	19207	12320982	HOUSING, DRIVE END	1
1	22	PAFZZ	19207	12320992	HOLDER, ELECTRICAL	1
1	23*	PAFZZ	19207	12320993	BRUSH, ELECTRICAL	2
1	24	PAFZZ	19207	12320994	COVER, BRUSH	1
1	25	PAFZZ	19207	12321014	SPACER, SLEEVE	4
1	26	PAFZZ	19207	12321017	WASHER	4
1	27	PAFZZ	19207	12321005	WASHER, FLAT	4
1	28	PAFZZ	19207	12321006	SCREW, MACHINE	4
1	29	PAFZZ	19207	12325872	SCREW, MACHINE	3
1	30	PAFZZ	96906	MS35338-41	WASHER, LOCK	3
1	31	PAFZZ	19207	12320999	PANEL ASSEMBLY	1
1	32	PAFZZ	19207	12325876	SPACER	1
1	33*	KFFZZ	19207	12320989	SEAL, ROTOR SHAFT	1
1	34*	KFFZZ	19207	12320985	BALL, BEARING, ANNU	1
1	35*	PAOZZ	19207	12321001	NUT, PLAIN, HEXAGON	8
1	36	PAFZZ	19207	12321015	WASHER, FLAT	3
1	37	PAFZZ	19207	12321013	INSULATOR, PLATE	1

SECTION II. REPAIR PARTS LIST (CONTINUED).

ILLUS						QTY
FIG	ITEM		PART			INC
NO.	NO.	SMR	FSCM	NUMBER	DESCRIPTION	IN
						UNIT
1	38	PAFZZ	19207	12325875	WASHER, CURVED SPR	6
1	39	PAFZZ	96906	MS90725-29	SCREW, CAP, HEXAGON	1
1	40	PAFZZ	19207	12321016	SCREW, CAP, HEX, COP	2
1	41	KFFZZ	19207	12320987	SEAL, ROTOR SHAFT	1
1	42	PAOZZ	96906	MS35338-46	WASHER, LOCK	2
1	KIT	PAFZZ	19207	5704976	PARTS KIT, ELECTRI	1
1	11				SEAL, ROTOR SHAFT	2
1	15				BEARING, ROLLER, C	1
1	18				NUT, SELF-LOCKING	1
1	23				BRUSH, ELECTRICAL	2
1	33				SEAL, ROTOR SHAFT	1
1	34				BALL, BEARING, ANN	1
1	41				SEAL, ROTOR SHAFT	1

* PART OF KIT P/N 5704976.

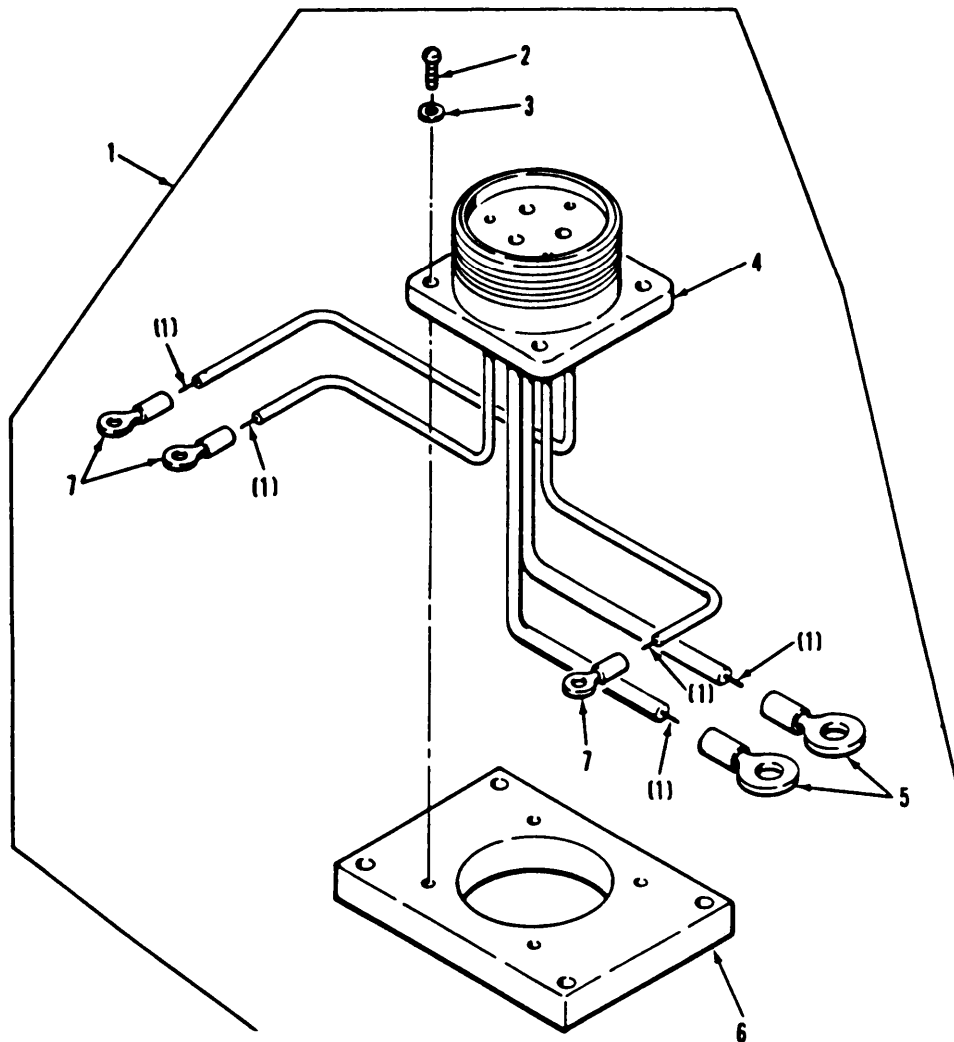

Figure 2. Connector and Lead Assembly.

ITEM NO.	SMR	FSCM	PART NUMBER	DESCRIPTION	QTY INC IN UNIT
GROUP 0601 GENERATOR CONTINUED					
Fig. 2 CONNECTOR AND LEAD ASSEMBLY					
12320997					
1	PAFFF	19207	12320997	CONNECTOR ASSEM	1
2	PAFZZ	96906	MS35265-45	SCREW,MACHINE	4
3	PAFZZ	96906	MS35338-42	WASHER,LOCK	4
4	XAFZZ	96906	MS3102R28-22P	CONNECTOR,RECE	1
5	PAFZZ	96906	MS20659-131	TERMINAL,LUG	2
6	XAFZZ	19207	12325873	PLATE,RETAININ	1
7	PAFZZ	96906	MS25036-102	TERMINAL,LUG	3

SECTION III. SPECIAL TOOLS LIST.

See Chapter 1, Section II, Special Tools and Equipment.

SECTION IV. NATIONAL STOCK NUMBER AND PART NUMBER INDEX

NATIONAL STOCK NUMBER INDEX

STOCK NUMBER	FIGURE NUMBER	ITEM NUMBER
5310-00-045-3299	1	2
5310-00-045-3299	2	3
5310-00-045-4007	1	30
5305-00-071-1322	1	5
5940-00-115-4991	2	5
5310-00-167-0826	1	7
5940-00-204-8966	2	7
5306-00-225-8494	1	39
5306-00-225-8514	1	20
5310-00-407-9566	1	19
5310-00-419-0876	1	8
5350-00-543-2752	2	2
5315-00-616-5524	1	17
5315-00-616-5529	1	6
5310-00-637-9541	1	42
5305-00-660-2625	1	1
2920-01-147-1514	1	21
2920-01-147-1515	1	9
2920-01-147-1516	1	10
5977-01-147-5850	1	22
5305-01-147-5864	1	40
2920-01-147-7895	1	31
2920-01-147-7904	1	16
2920-01-147-7905	2	1
2920-01-147-7906	1	24
2920-01-147-7907	1	12
5970-01-147-7913	1	23
2920-01-147-7914	1	3
3120-01-147-7916	1	14
5365-01-147-7917	1	25
5970-01-147-7918	1	37
5310-01-155-2572	1	35
5310-01-155-5250	1	36
5305-01-155-8645	1	29
5306-01-156-7663	1	4
5305-01-157-0876	1	28
5310-01-161-6188	1	27
6115-01-162-7062	1	KIT

TM9-2920-257-30&P
 PART NUMBER INDEX

PART NUMBER	FSCM	FIGURE NUMBER	ITEM NUMBER
AN960-1216	88044	1	7
MS20659-131	96906	2	5
MS21245L12	96906	1	8
MS25036-102	96906	2	7
MS3102R28-22P	96906	2	4
MS35265-45	96906	2	2
MS35265-47	96906	1	1
MS35338-41	96906	1	30
MS35338-42	96906	1	2
MS35338-42	96906	2	3
MS35338-45	96906	1	19
MS35338-46	96906	1	42
MS35756-10	96906	1	17
MS35756-16	96906	1	6
MS51960-65	96906	1	5
MS51988-12	96906	1	18
MS90725-29	96906	1	39
MS90725-50	96906	1	20
12320979	19207	1	13
12320980	19207	1	10
12320981	19207	1	9
12320982	19207	1	21
12320983	19207	1	16
12320984	19207	1	15
12320985	19207	1	34
12320986	19207	1	11
12320987	19207	1	41
12320989	19207	1	33
12320992	19207	1	22
12320993	19207	1	23
12320994	19207	1	24
12320997	19207	2	1
12320999	19207	1	31
12321001	19207	1	35
12321005	19207	1	27
12321006	19207	1	28
12321010	19207	1	3
12321011	19207	1	14
12321012	19207	1	12
12321013	19207	1	37
12321014	19207	1	25
12321015	19207	1	36
12321016	19207	1	40

PART NUMBER INDEX (CONTINUED)

PART NUMBER	FSCM	FIGURE NUMBER	ITEM NUMBER
12321017	19207	1	26
12325869	19207	1	4
12325876	19207	1	32
5704976	19207	1	KIT

APPENDIX D

TOOL AND EQUIPMENT REQUIREMENTS

ITEM NUMBER	LEVEL	NATIONAL STOCK NUMBER	NOMENCLATURE	TOOL PART NUMBER
1	F	4910-00-754-0705	Shop Equipment Automotive Maintenance and Repair, Field Maintenance	
2	F	5180-00-754-0655	Tool Kit, Automotive Fuel and Electric System Repair	
3	F	6625-00-553-0142	Multimeter	TS-352 B/U or equal
4	F	3444-00-243-2654	Press, Arbor, Hand	
5	F	4910-00-767-0218	Test Stand, Generator 500 AMP (Sun)	
6	F	4910-01-041-8161	Test Stand, Generator 500 AMP (UMC)	
7	F	5120-00-740-3345	Puller, Mechanical Three-legged	
8	F	5120-00-293-1439	Vice, Machinists 4" Jaws, 6" Opening	

APPENDIX E

TEST STAND PROCEDURES

E-1. GENERAL

After repair of the generator it must be bench tested to verify correct operation. Follow the procedures below to calibrate test stand tachometer, set base settings for the test stands, and then perform tests on the 200 ampere generator/regulator and generator.

E-2. CALIBRATION

Military vehicle generators are equipped with various size pulleys, such as 3-, 3 1/2-, and 4-inch diameter. The 500-ampere test stand has a 4-inch pulley. Since the test stand tachometer reads drive head speed, the tachometer must be calibrated when a generator has a pulley larger or smaller than 4 inches. To calibrate the speed of the generator use formula below.

Formula: a = Test speed of test generator (normally lowest rated output speed as indicated by specifications).

4 = Diameter of drive pulley on test stand.

b = Value of a x 4.

c = Diameter of pulley on generator to be tested.

e = Value of b divided by c (this value will indicate the speed of the driven pulley when the test stand speed (a) is at selected speed).

$$a \times 4 = \frac{b}{c} = e$$

Example: To test a generator with a 3-inch pulley, determine lowest rated speed of generator. If rated RPM for a generator is 2,000 RPM to 8,000 RPM, select 2,000 RPM as test speed.

Increase test stand speed to 2,000 RPM with vari-drive speed control. Turn the calibrate pulley control to calibrate position.

Turn the calibrate knob to increase reading on the tachometer to value determined by e (speed of test generator) in above formula. Increase or reduce test stand speed with vari-drive control until tachometer indicates desired test speed (2,000 RPM). In the formula below, the 3-inch pulley on the test generator will be turning 2,666 RPM when the test stand tachometer indicates 2,000 RPM.

$$2000 \times 4 = \frac{8000}{3} = 2666 \text{ RPM}$$

E-3. BASE SETTING FOR UMC SWITCHES AND CONTROLS
(Part No 7458 and 7458-2)

CAUTION

Make certain all test stand switches and controls are in positions listed below before testing to prevent damage to test stand or component by application of excessive power.

The base setting for UMC controls and switches:

- | | |
|--|------------------|
| a. DC load ammeter range switch | X 10 |
| b. DC field ammeter range switch | X 6 . |
| c. Millivoltmeter | |
| (1) Range switch | X 10 |
| (2) Millivoltmeter (press to read switch) | OFF |
| d. DC voltmeter | |
| (1) Range switch | X 5 |
| (2) Select switch | RECT/GEN |
| e. Tachometer | |
| (1) Select switch | DIRECT DRIVE |
| (2) Pulley calibration knob | COUNTERCLOCKWISE |
| f. AC ammeter | |
| (1) Range switch | X 2 |
| (2) Select. switch | T1 |
| g. AC voltmeter | |
| (1) Range switch | X 2 |
| (2) Select switch | T1 - T2 |
| h. External field exciter switch (AC system) | OFF |

i. Generator field	INT GND
j. Polarity reversing switch	NEG GND
k. Field circuit	OFF
l. Fine control switch (0-5)	OFF
m. Field current increase (0-S)	COUNTERCLOCKWISE
n Field circuit (rheostat 0-30)	COUNTERCLOCKWISE
o Battery circuit selector	OFF
p Circuit breakers	DOWN (Press to ensure CBS are down)
q Regulator check, fixed resistance method	OFF
r. DC variable volts	OFF
s Load selection (all switches)	OFF
t Master load disconnect	OFF
u. Variable load increase	COUNTERCLOCKWISE
v. Voltage adjusting increase (VAR)	COUNTERCLOCKWISE
w Field shorting (spring-loaded)	OFF
x Starter rheostat	Approximately three turns COUNTERCLOCKWISE from fully CLOCKWISE
y Starter test	OFF
z Equalizer coil test	OFF
aa. Auxiliary start	OFF
ab. Ignition switch	OFF
ac. Bus bars	
(1) B+ and G+	In place
(2) B- and G-	In place
ad. DC variable power supply 0-32 VDC (front panel)	COUNTERCLOCKWISE
ae. Charge time control	OFF
af. Battery charger variable load	COUNTERCLOCKWISE
ag. D-sensing switch	OFF
(New UMC test stand no. 7458-2 has D-sensing switch normally OFF.)	

Reference- Base setting for SUN test stand.

External master power switch	OFF
Main power switch	OFF
Motor drive set for CLOCKWISE rotation of generator	
DC load ammeter	500 amperes
DC field ammeter	30 amperes
Millivolt meter	9 volts and OFF
DC voltmeter	50 volts and RECT/GEN
Tachometer	Direct drive
AC ammeter	500 amperes and phase A
AC voltmeter	50 volts and OFF
400-ampere control box	Voltage adjust fully COUNTERCLOCKWISE
Equalizer coil test	OFF
Ignition switch	OFF
Power supply switch	OFF and rheostat fully COUNTERCLOCKWISE
Battery charger switch	OFF and rheostat fully COUNTERCLOCKWISE
External field	OFF
Field common	Negative (-)
Field circuit switch	Regulator
Relay lamp	OFF
Regulator load resistor selector	OFF
Current polarity	OFF
Starter test switch	OFF and stator voltage adjusted COUNTERCLOCKWISE
All load switches	OFF
Field current switches	OFF
Field current rheostat	Fully COUNTERCLOCKWISE
Variable load	Fully COUNTERCLOCKWISE
Regulator section bus bars	
(1) B+ and G+	In place
(2) B- and G-	In place

E-4. 200 AMP BENCH TESTS

a. Generator test

CAUTION

Follow steps as written or voltage spikes may damage test equipment or pop circuit breaker.

1. Place test stand controls and switches in base settings (para E-3).
2. Install bracket (fig. F-6) on test stand.
3. Install pulley (UMC part no. 89335) on test stand.
4. Install pulley assembly 12314043 (3020-01-146-8942) on generator.
5. Place generator in bracket. Install three belts (UMC part no. 3L350) between pulleys. Check belt tension and alignment. Lock generator in bracket with chain vise.
6. Verify bus bars are installed from B+ to G+ and B- to G-.
7. Connect generator to test stand cables (see figures F-7 through F-12).
8. Adjust rheostat (fig. F-4) maximum resistance.
9. Verify main circuit breaker on test stand is ON.
10. Turn BATTERY CIRCUIT SELECTOR to 24 VOLTS.
11. Turn FIELD CIRCUIT switch to REGULATOR. Note: on -4 test stand DC voltmeter to RECT/GEN.
12. Turn MASTER LOAD DISCONNECT switch ON.
13. Press START button.
14. Increase test stand speed to 2000 RPM.
15. Check output voltage for 28 + 1 volts. If necessary, adjust rheostat voltage to obtain 28 + 1 volts.
16. Reading DC RANGE ammeter, add incremental loads up to 200 AMPS. Adjust rheostat as needed to maintain voltage.
17. If 200 AMPS at 2000 RPM cannot be obtained at all load settings, generator is defective.
18. Turn rheostat until 24 VDC is obtained. Repeat until all applied loads are removed. Turn off applied loads one at a time, readjusting rheostat to 24 VDC each time a load is removed.
19. Reduce test stand speed to 1000 RPM.

20. Push STOP button. Wait for test stand to come to a complete stop.

21. Return test stand to base settings (para E-3).

22. Remove generator from test stand.

b. Generator/Regulator test

CAUTION

Follow steps as written or voltage spikes may damage test equipment or pop circuit breaker.

NOTE

Perform generator test first.

1. Place test stand switches and controls in base settings (para E-3).

2. Install bracket (fig. F-5) on test stand.

3. Install pulley (UMC part no. 89335) on test stand.

4. Install pulley 12314043 on generator.

5. Place generator in bracket. Install three belts (part no. 3L350-G) between pulleys. Check belt tension and alignment. Lock down generator with chain vise.

6. Verify bus bars are installed from B+ to G+ and B- to G-.

7. Connect generator/regulator test stand cables (see figures F-7 through F-12).

8. Verify main circuit breaker on test stand is ON.

9. Turn BATTERY CIRCUIT SELECTOR to 24 VOLTS. (Sun reference - Read BATTERY SELECT).

10. Turn MASTER LOAD DISCONNECT switch ON.

11. Press START button.

12. Increase test stand speed to 2000 RPM.

13. Check output voltage for 28 + .5 volts. If necessary, adjust regulator output screw to obtain 28 + .5 volts.

14. Verify test stand is operating at 2000 RPM.

15. Check output voltage which should be 28 + .5 volts. Read DC LOAD AMMETER. (Sun reference - Read DC AMMETER LOAD AND STARTER OUTPUT BATTERY CHARGE CURRENT).

16. Add incremental loads up to 200 amps. Voltage should remain constant.
17. If 28 volts cannot be sustained at various settings, regulator is defective.
18. Reduce loads one at a time, until load is zero at completion of test.
19. Reduce test stand speed to 1000 RPM.
20. Press STOP button. Wait for test stand to come to a complete stop.
21. Return test stand switches and controls to base settings (para E-3).
22. Remove generator and regulator from test stand.

28.0 VOLT PERFORMANCE CURVES
IN 75°F ±5° AMBIENT (HOT STABILIZED)

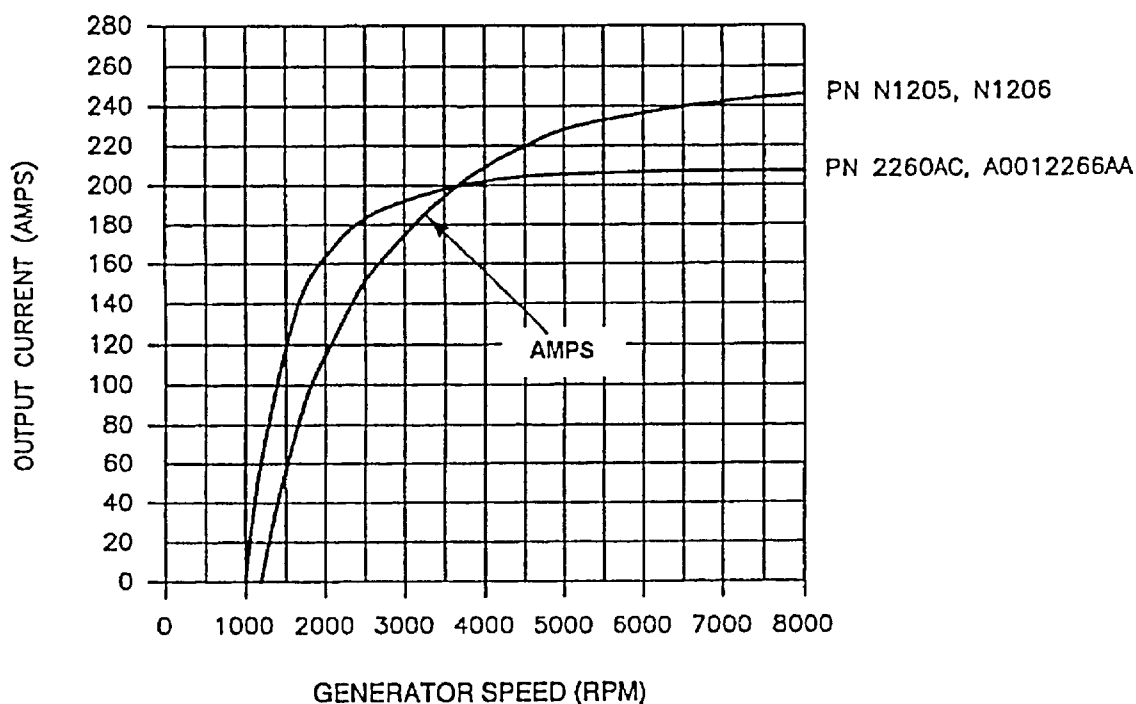

Figure E-1. 200 AMP Generator Performance Curves

APPENDIX F

ILLUSTRATED LIST OF MANUFACTURED ITEMS

F-1. GENERAL

This appendix includes complete instructions for making items authorized to be manufactured or fabricated at intermediate direct support maintenance.

F-2. Generator disassemble and assembly requires the use of

F-2. FABRICATED TOOLS

Generator disassembly and assembly requires the use of fabricated tools. See figures F-1 through F-3 for materials and dimensions required to fabricate the necessary tools.

F-3. SPECIAL EQUIPMENT

a. A matched set of 35-inch V-belts (O.D.), NSN 3030-00-834-5935 is required for testing the generator.

NOTE

Matched set of V-belts, NSN 3030-00-834-5935 is a four belt set; only three belts are needed.

b. A 50 OHM, 300 watt rheostat, NSN 5905-00-497-0732, is needed for testing generator. See figure F-4.

c. Testing generator requires fabricating special wiring harnesses, and a special bracket and a rheostat mounting box to be used with the test stand. See figures F-5 and F-6 for materials and dimensions required for bracket and rheostat box fabrication. See figures F-7 through F-12 for materials and dimensions for wiring harness fabrication.

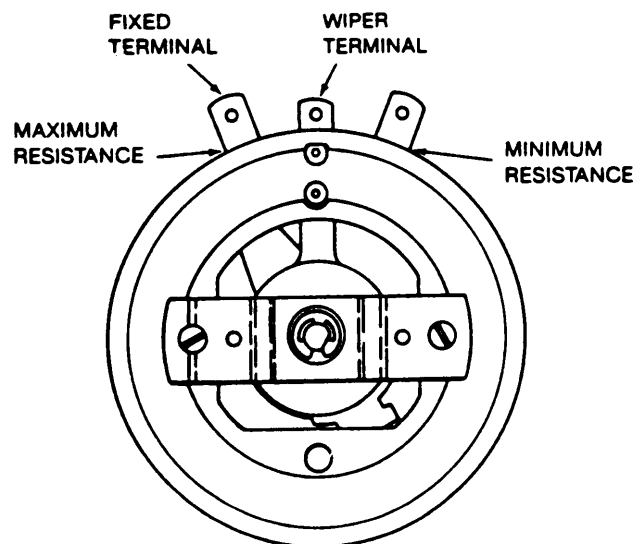
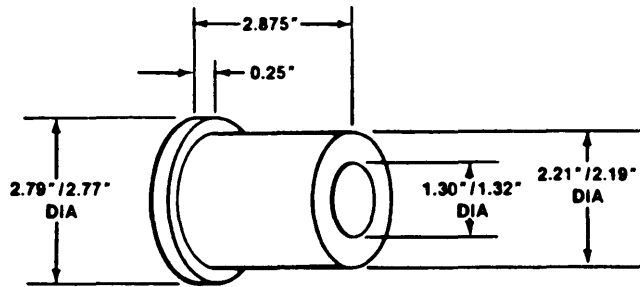

Figure F-4. Rheostat

Fabricated Tools for Generator Disassembly and Assembly.



MATERIAL: STEEL, CARBON, C1108 THRU C 1112,
B 1112 OR B 1113, CF OR CD, SPEC QQ-S-637

Figure F- 1. BALL BEARING TOOL

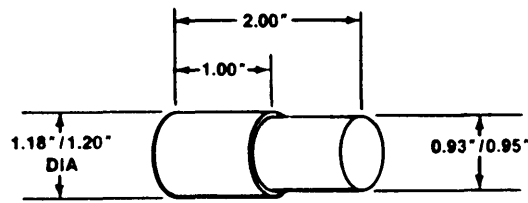

MATERIAL: STEEL, CARBON C 1108 THRU C 1113,
B 1112 OR B 1113, CF OR CD, SPEC QQ-S-637

Figure F-2. ROLLER BEARING TOOL

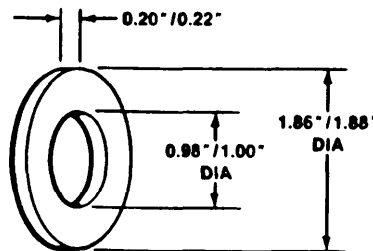

MATERIAL: STEEL, CARBON, 1008 THRU 1020, SHEET OR STRIP,
HRCO, P&O, SPEC QQ-S-698, 0.200-THICK

Figure F-3. ASSEMBLY SPACER

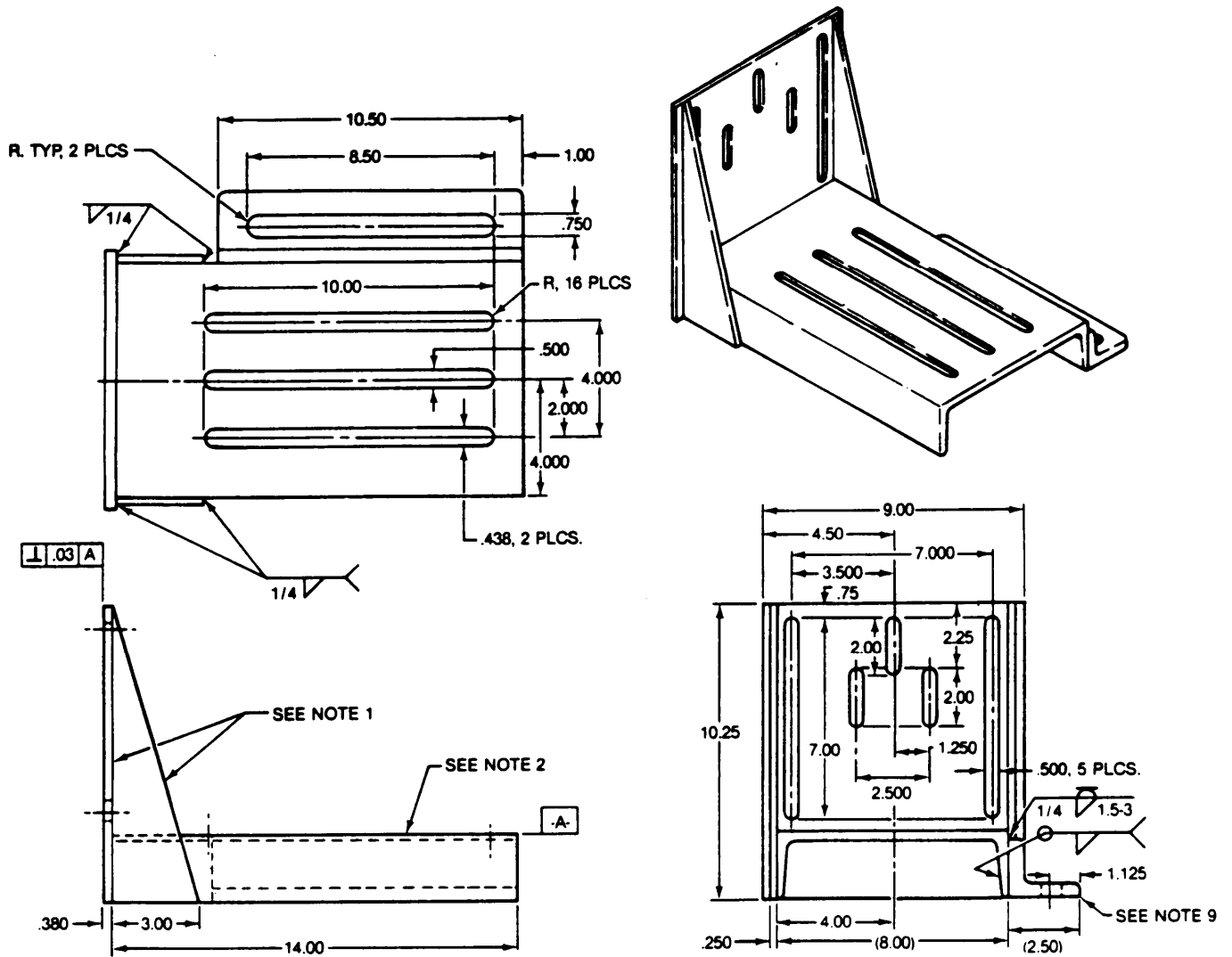

PART NO 11020555

NOTES:

1. MATERIAL: STEEL PLATE, IAW ASTM A36.
2. MATERIAL STEEL CHANNEL, C8 x 11.5 IAW ASTM A36.
3. ALL MACHINED SURFACES TO BE 250.
4. FOR INTERPRETATION OF: DIMENSIONING AND TOLERANCING, SEE ANSI Y145. DRAWING STANDARDS. SEE DOD-STD-100.
5. REMOVE BURRS AND BREAK ALL SHARP EDGES.
6. MARK PART NO. IAW MIL-STD-130.
7. FINISH 5.1.1 + 21.3 OF MIL-STD-171. COLOR-GRAY, NO. 26037 OF MIL-STD-595
8. WELD IAW MIL-STD-1261 CLASS I.
9. MATERIAL: STEEL ANGLE. < 2 1/2 x 2 x 1/2 IAW ASTM A36.

Figure F - 5. Test Stand Bracket

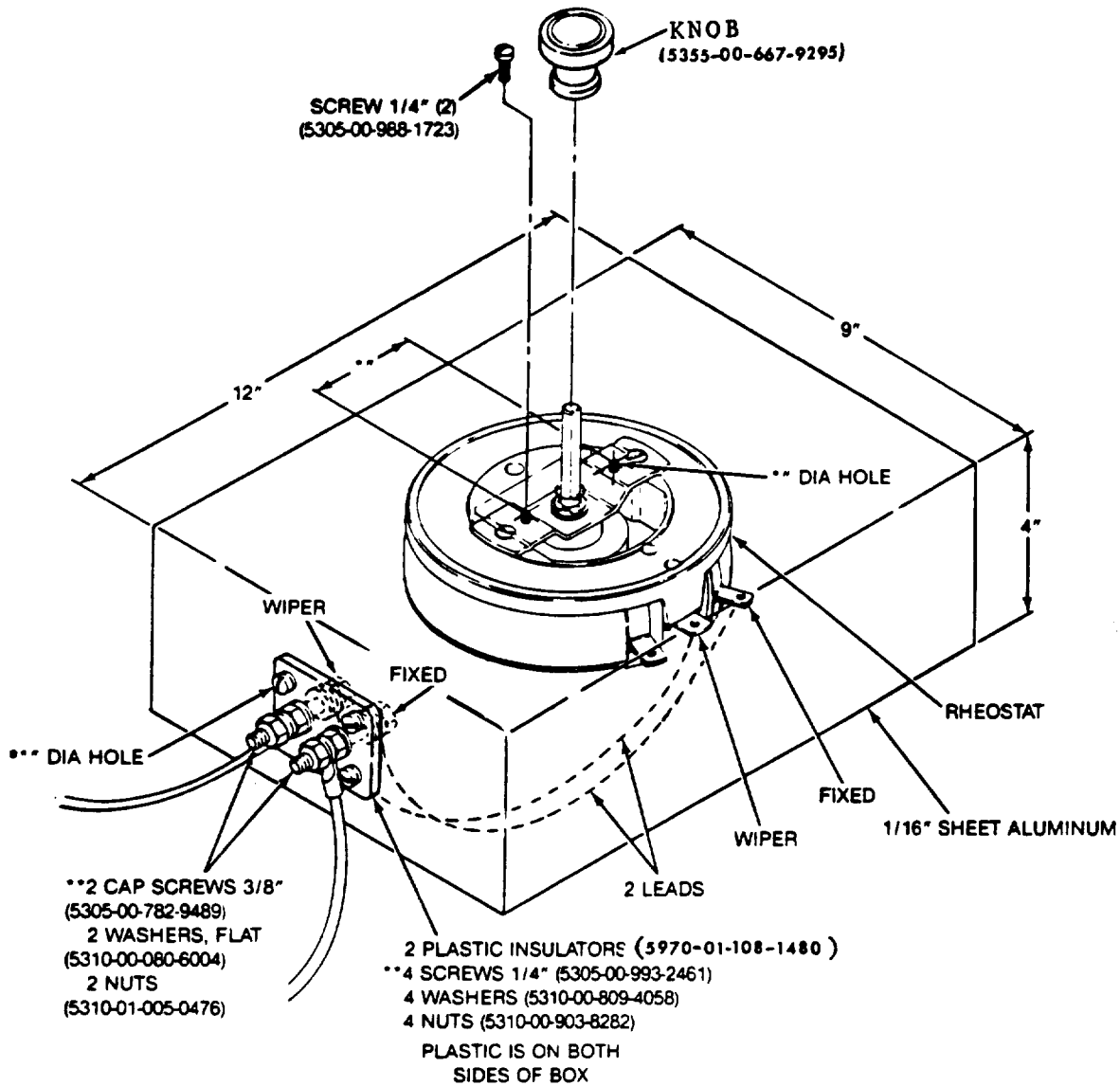

*MEASURE RHEOSTAT. DRILL HOLES IN COVER AS NEEDED
 **DRILL HOLES IN SIDE OF BOX AS NEEDED

WARNING

To prevent electrical shock, cut sheet metal away from cap screws so they contact only the plastic insulators, not the metal box.

Note: Fabricate rheostat mounting box according to materials and dimensions above.

Figure F-6 Rheostat Mounting Box

NOTE

The length tolerance for all cables is ± 0.25 inch.

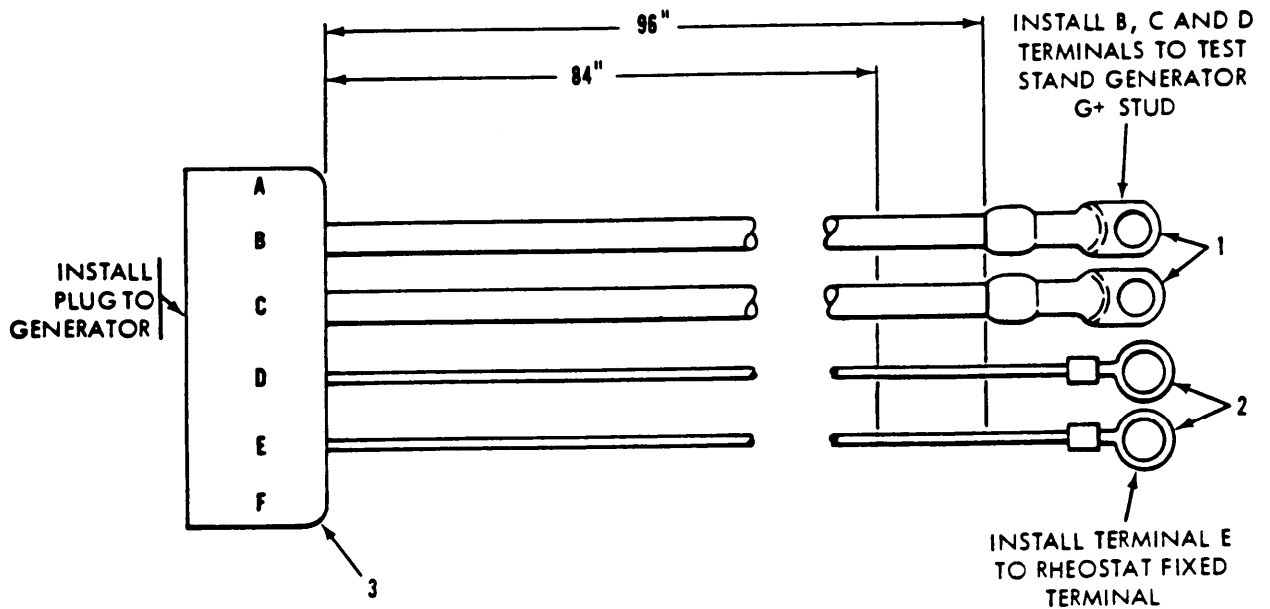

Legend:

- | | |
|--|---|
| <p>1 Cable - M13486/1-11
(6145-00-538-8219)
Terminal - 8689221
(5940-01-170-4956)
Band marker - M43436/1-1
(9905-00-752-4649)</p> | <p>3 Connector, plug, - 8724262
(5935-00-730-7325)
Insert, elec - 10874855
(5935-00-784-1701)
Nut - 7723309
(5310-00-393-6685)
Nut - 7716634
(5975-00-771-6634)
AR-Rod - 8724768
(9390-00-485-9885)
AR-Rod - 8724763
(9390-00-180-7289)</p> |
| <p>2 Cable - M13486-1-7
(6145-00-705-6678)
Terminal - MS25036-155
(5940-00-660-3633)
Band marker - M43436/1-1
(9905-00-752-4649)</p> | |

Figure F-7. Generator Test Harness - 19207-12349685

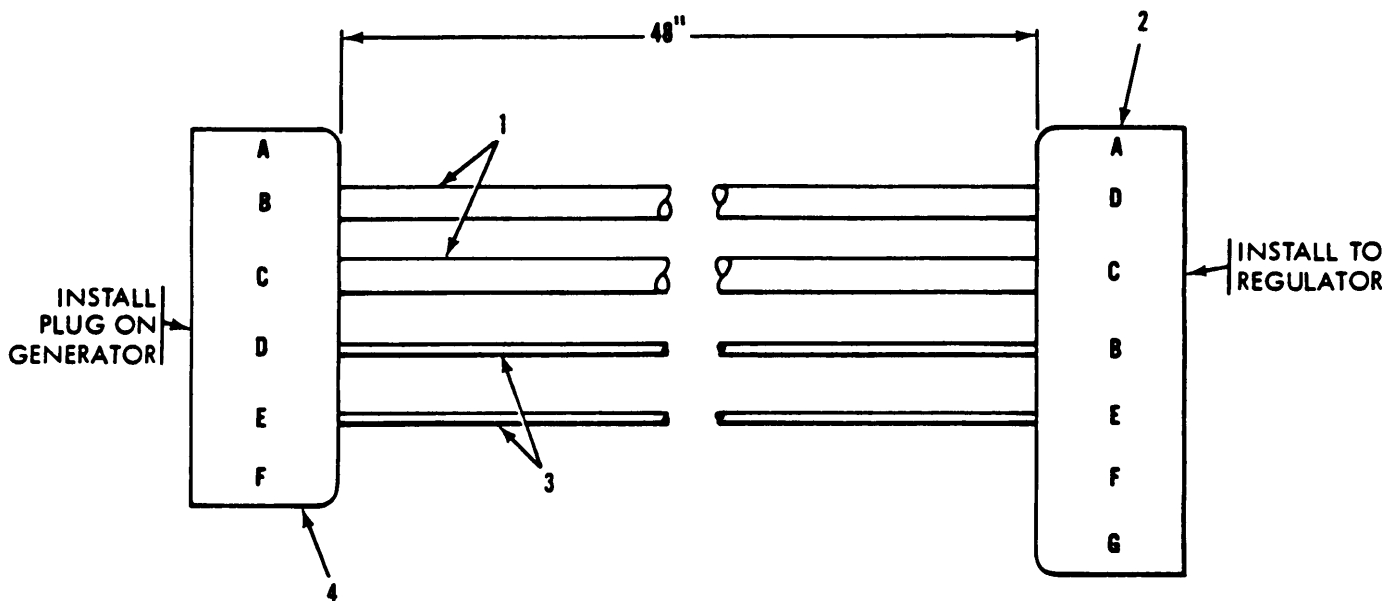

Legend:

- | | |
|--|---|
| <p>1 Cable - M13486/1-11
(6145-00-538-8219)</p> <p>2 Connector, plug - 8724262
(5935-00-730-7325)
Insert, elec - 10874855
(5935-00-784-1701)
Nut - 7723309
(5310-00-393-6685)
Nut - 7716634
(5975-00-771-6634)
AR-Rod - 8724763
(9390-00-180-7289)
AR-Rod - 8724768
(9390-00-485-9885)</p> | <p>3 Cable - M13486-1-7
(6145-00-705-6678)</p> <p>4 Connector, plug - 8724259
(5935-00-081-0400)
Nut - 7716634-1
(5975-01-151-7033)
Bushing, rubber - 8341848
(5365-00-303-4841)
Nut - 7723309
(5310-00-393-6685)
AR-Rod - 8724763
(9390-00-180-7289)</p> |
|--|---|

Figure F-8. Generator/Regulator Test Harness - 19207-12349686

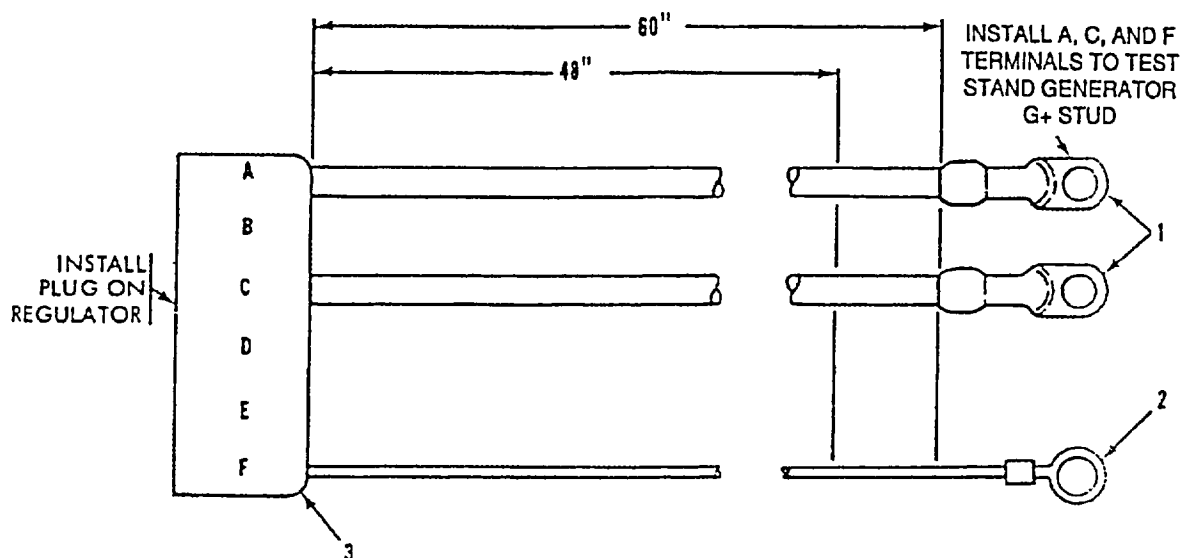

Legend:

- | | |
|--|--|
| <p>1 Cable - M13486/1-11
(6145-00-538-8219)
Terminal - 8689221
(5940-01-170-4956)
Band marker - M43436/1-1
(9905-00-752-4649)</p> | <p>3 Connector, plug - 8724262
(5935-00-730-7325)
Insert, elec - 10874855
(5935-00-784-1701)
Nut - 7723309
(5310-00-393-6685)
Nut - 7716634-1
(5975-01-151-7033)
AR-Rod - 8724763
(9390-00-180-7289)
AR-Rod - 8724768
(9390-00-485-9885)</p> |
| <p>2 Cable - M13486-1-7
(6145-00-705-6678)
Terminal - MS25036-155
(5940-00-660-3633)
Band marker - M43436/1-1
(9905-00-752-4649)</p> | |

Figure F-9. Generator/Regulator Test Harness - 19207 - 12349687

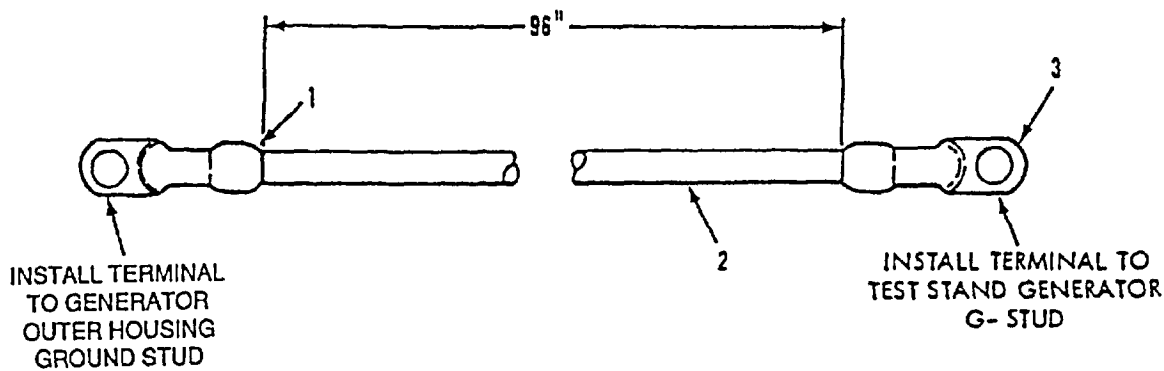

Legend:

- | | |
|---|--|
| 1 Terminal - 7064829
(5940-00-520-2447) | 3 Terminal - 8689221
(5940-01-170-4956) |
| 2 Cable - M43436/1-11
(6145-00-538-8219) | |

Figure F-10. Ground Cable - 19207-12349684

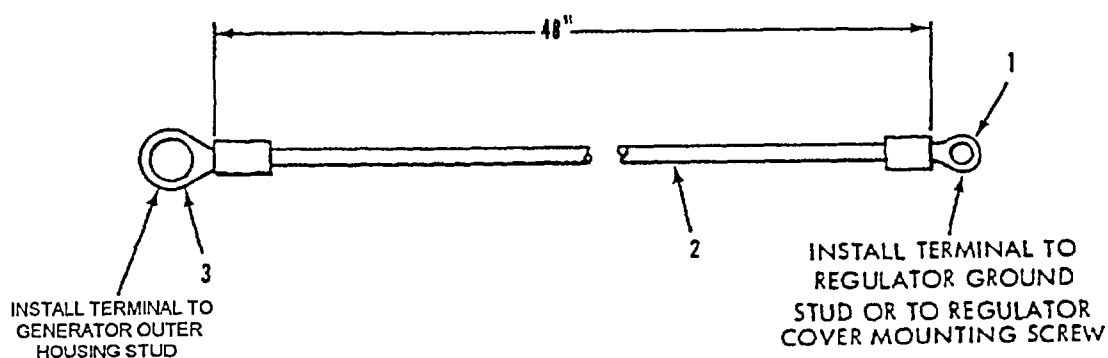

Legend:

- | | |
|--|--|
| 1 Terminal - MS25036-108
(5940-00-143-4780) | 3 Terminal - MS25036-155
(5940-00-660-3633) |
| 2 Cable - M13486/1-6
(6145-00-705-6678) | |

Figure F-11. Ground Cable - 19207 - 12349682

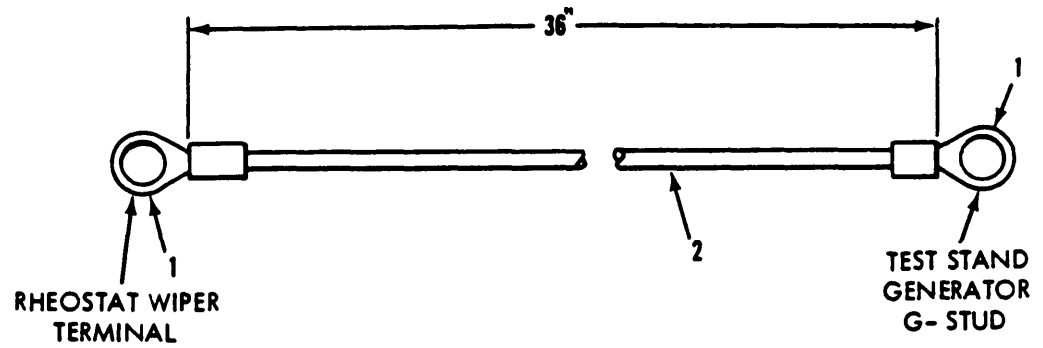

Legend:

- 1 Terminal - MS25036-155
(5940-00-660-3633)
- 2 Cable - M13486-1-7
(6145-00-705-6678)

Figure F-12. Ground Cable - 19207-12349683

By Order of the Secretary of the Army:

Official:

JOHN A. WICKHAM, JR.
General, United States Army
Chief of Staff

R.L. DILWORTH
Brigadier General United States Army
The Adjutant General

Distribution:

To be distributed in accordance with DA Form
12-37, Direct Support requirements for Carrier,
Personnel, M113A3 (RISE), Command Post Carrier,
M577A2, and DA Form 12-32, Direct Support Require-
ments for Chaparral, M730A2

RECOMMENDED CHANGES TO EQUIPMENT TECHNICAL PUBLICATIONS



THEN... JOT DOWN THE DOPE ABOUT IT ON THIS FORM. CAREFULLY TEAR IT OUT. FOLD IT AND DROP IT IN THE MAIL!

SOMETHING WRONG WITH THIS PUBLICATION?

FROM: (PRINT YOUR UNIT'S COMPLETE ADDRESS)
 SP/4 J. Byrd
 Co. A 134 Mt. Bn
 A.P.O. New York 09169

DATE SENT
 1 June 1987

PUBLICATION NUMBER
 TM 9-2920-257-30&P

PUBLICATION DATE
 May 1987

PUBLICATION TITLE
 GENERATOR, ALTERNATING CURRENT,
 200 AMPERES

BE EXACT - PIN-POINT WHERE IT IS

PAGE NO	PARA-GRAPH	FIGURE NO	TABLE NO
B-1			

IN THIS SPACE TELL WHAT IS WRONG AND WHAT SHOULD BE DONE ABOUT IT:

Expendable list, item #3; Enamel, Epoxy P/N (11927) 32230 (M), shows "gl" in U/M column, with no NSN listed. Is there an NSN for a smaller size, such as a pint or a quart?

SAMPLE

PRINTED NAME, GRADE OR TITLE, AND TELEPHONE NUMBER
 J. Byrd Sp/4 301-278-4487

SIGN HERE

RECOMMENDED CHANGES TO EQUIPMENT TECHNICAL PUBLICATIONS



SOMETHING WRONG

WITH THIS PUBLICATION?

THEN JOT DOWN THE DOPE ABOUT IT ON THIS FORM CAREFULLY TEAR IT OUT, FOLD IT AND DROP IT IN THE MAIL

FROM (PRINT YOUR UNIT'S COMPLETE ADDRESS)

DATE SENT

PUBLICATION NUMBER
TM 9-2920-257-30&P

PUBLICATION DATE
May 1987

PUBLICATION TITLE
GENERATOR, ALTERNATING CURRENT,
200 AMPERES

BE EXACT. PIN POINT WHERE IT IS

PAGE NO	PARA-GRAPH	FIGURE NO	TABLE NO

IN THIS SPACE TELL WHAT IS WRONG AND WHAT SHOULD BE DONE ABOUT IT:

PRINTED NAME GRADE OR TITLE AND TELEPHONE NUMBER

SIGN HERE

DA ^{FORM} 1 JUL 79 2028-2

PREVIOUS EDITIONS ARE OBSOLETE

PS IF YOUR OUTFIT WANTS TO KNOW ABOUT YOUR RECOMMENDATION MAKE A CARBON COPY OF THIS AND GIVE IT TO YOUR HEADQUARTERS TA 480814

FILL IN YOUR
UNIT'S ADDRESS



FOLD BACK

DEPARTMENT OF THE ARMY



OFFICIAL BUSINESS

NO POSTAGE
NECESSARY
IF MAILED
IN THE
UNITED STATES

BUSINESS REPLY MAIL
FIRST CLASS BRM PERMIT NO. 82 ROCK ISLAND, IL

POSTAGE WILL BE PAID BY ROCK ISLAND ARSENAL

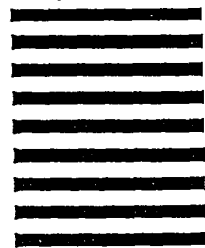

HQ, US ARMY TANK-AUTOMOTIVE AND
ARMAMENTS COMMAND
ATTN: AMSTA-LC-CI (TECH PUBS CONTROL POINT)
ROCK ISLAND, IL 61201-9948

TEAR ALONG PERFORATED LINE

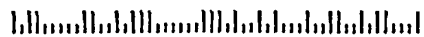

THE METRIC SYSTEM AND EQUIVALENTS

LINEAR MEASURE

- 1 Centimeter = 10 Millimeters = 0.01 Meters = 0.3937 Inches
- 1 Meter = 100 Centimeters = 1000 Millimeters = 39.37 Inches
- 1 Kilometer = 1000 Meters = 0.621 Miles

WEIGHTS

- 1 Gram = 0.001 Kilograms = 1000 Milligrams = 0.035 Ounces
- 1 Kilogram = 1000 Grams = 2.2 Lb
- 1 Metric Ton = 1000 Kilograms = 1 Megagram = 1.1 Short Tons

LIQUID MEASURE

- 1 Milliliter = 0.001 Liters = 0.0338 Fluid Ounces
- 1 Liter = 1000 Milliliters = 33.82 Fluid Ounces

SQUARE MEASURE

- 1 Sq Centimeter = 100 Sq Millimeters = 0.155 Sq Inches
- 1 Sq Meter = 10,000 Sq Centimeters = 10.76 Sq Feet
- 1 Sq Kilometer = 1,000,000 Sq Meters = 0.386 Sq Miles

CUBIC MEASURE

- 1 Cu Centimeter = 1000 Cu Millimeters = 0.06 Cu Inches
- 1 Cu Meter = 1,000,000 Cu Centimeters = 35.31 Cu Feet

TEMPERATURE

- $5/9 (^{\circ}\text{F} - 32) = ^{\circ}\text{C}$
- 212° Fahrenheit is equivalent to 100° Celsius
- 90° Fahrenheit is equivalent to 32° Celsius
- 32° Fahrenheit is equivalent to 0° Celsius
- $9/5 \text{ C} + 32 = ^{\circ}\text{F}$

APPROXIMATE CONVERSION FACTORS

TO CHANGE	TO	MULTIPLY BY
Inches	Centimeters	2.540
Feet	Meters	0.305
Yards	Meters	0.914
Miles	Kilometers	1.609
Square Inches	Square Centimeters	6.451
Square Feet	Square Meters	0.093
Square Yards	Square Meters	0.836
Square Miles	Square Kilometers	2.590
Acres	Square Hectometers	0.405
Cubic Feet	Cubic Meters	0.028
Cubic Yards	Cubic Meters	0.765
Fluid Ounces	Milliliter	29.573
Pints	Liters	0.473
Quarts	Liters	0.946
Gallons	Liters	3.785
Ounces	Grams	28.349
Pounds	Kilograms	0.454
Short Tons	Metric Tons	0.907
Inch-pounds	Centimeter-kilograms	1.152
Foot-pounds	Meter-kilograms	0.138
Pounds per Square Inch	Kilopascals	6.895
Miles per Gallon	Kilometers per Liter	0.425
Miles per Hour	Kilometers per Hour	1.609

TO CHANGE	TO	MULTIPLY BY
Centimeters	Inches	0.394
Meters	Feet	3.280
Meters	Yards	1.094
Kilometers	Miles	0.621
Square Centimeters	Square Inches	0.155
Square Meters	Square Feet	10.764
Square Meters	Square Yards	1.196
Square Kilometers	Square Miles	0.386
Square Hectometers	Acres	2.471
Cubic Meters	Cubic Feet	35.315
Cubic Meters	Cubic Yards	1.308
Milliliters	Fluid Ounces	0.034
Liters	Pints	2.113
Liters	Quarts	1.057
Liters	Gallons	0.264
Grams	Ounces	0.035
Kilograms	Pounds	2.205
Metric Tons	Short Tons	1.102
Centimeter-kilograms	Inch-pounds	0.868
Meter-kilograms	Foot-pounds	7.233
Kilopascals	Pounds per Square Inch	0.145
Kilometers per Liter	Miles per Gallon	2.354
Kilometers per Hour	Miles per Hour	0.621

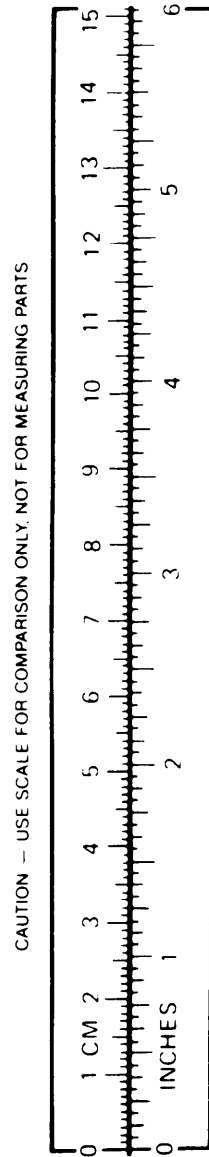

PIN: 062479-001